

alpha Basic Line

WORM GEARBOXES CVH / CVS

If the focus is on smooth running, smooth synchronization properties, and continuous operation, the V-Drive Basic is the right choice for you.

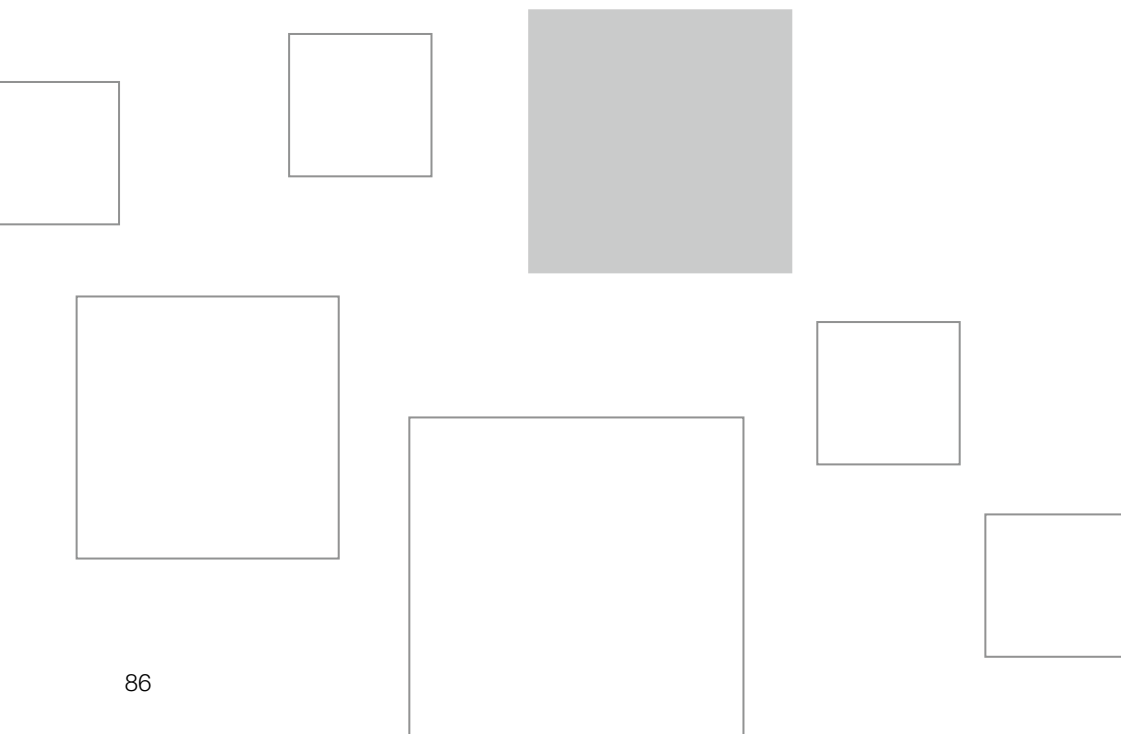

CVH

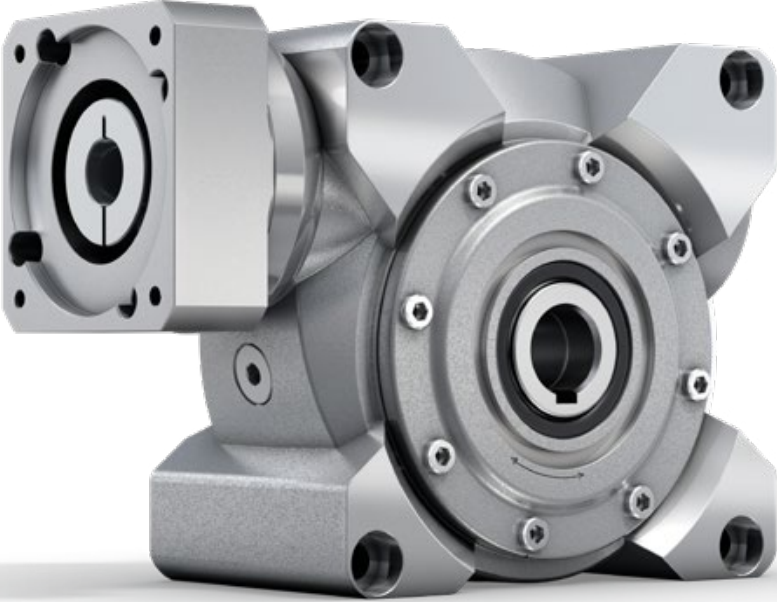

CVS

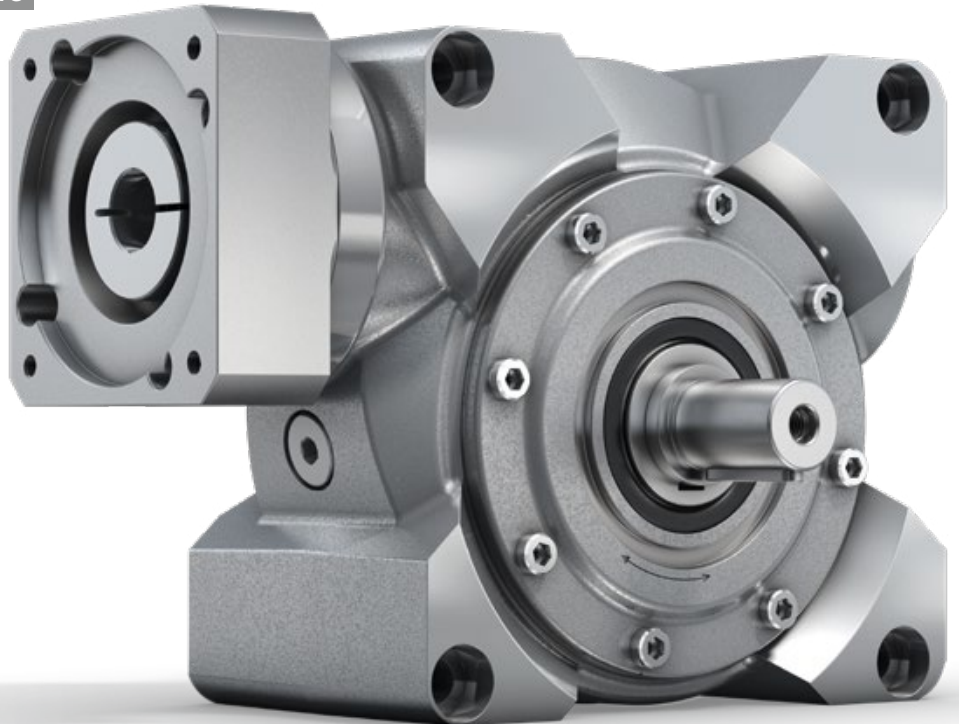

alpha Basic Line in action

COMPACT AND HIGH-PERFORMANCE WORM GEARBOX

in electronics production

When developing our customer's new rotary converter series, we had to meet three main objectives: offer the ability to dynamically adapt the conversion rate, minimize the cycle times, and improve the positioning accuracy.

With the V-Drive Basic by WITTENSTEIN alpha, the decision was made in favor of a high-performance servo worm gearbox which can be perfectly integrated into the system thanks to its compact design form.

This is made possible by a newly developed involute gearing of the worm gear set, which delivers a significant improvement in positioning and repetition accuracy with increased efficiency and very good running characteristics compared to the other converters. This provides a reduction in cycle times and therefore an increase in throughput performance in the application for feeding workpiece carriers or masks into various assembly, production, and inspection processes.

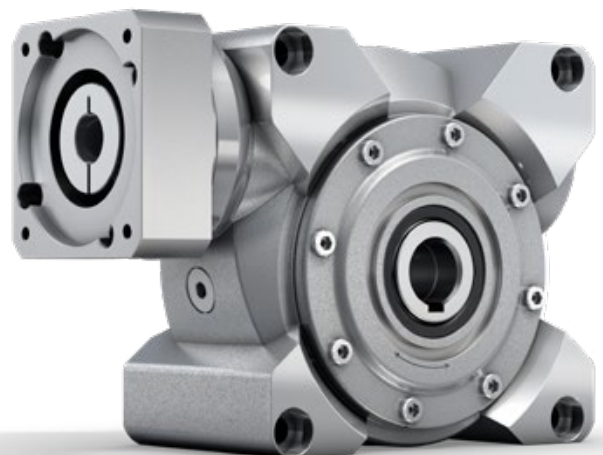

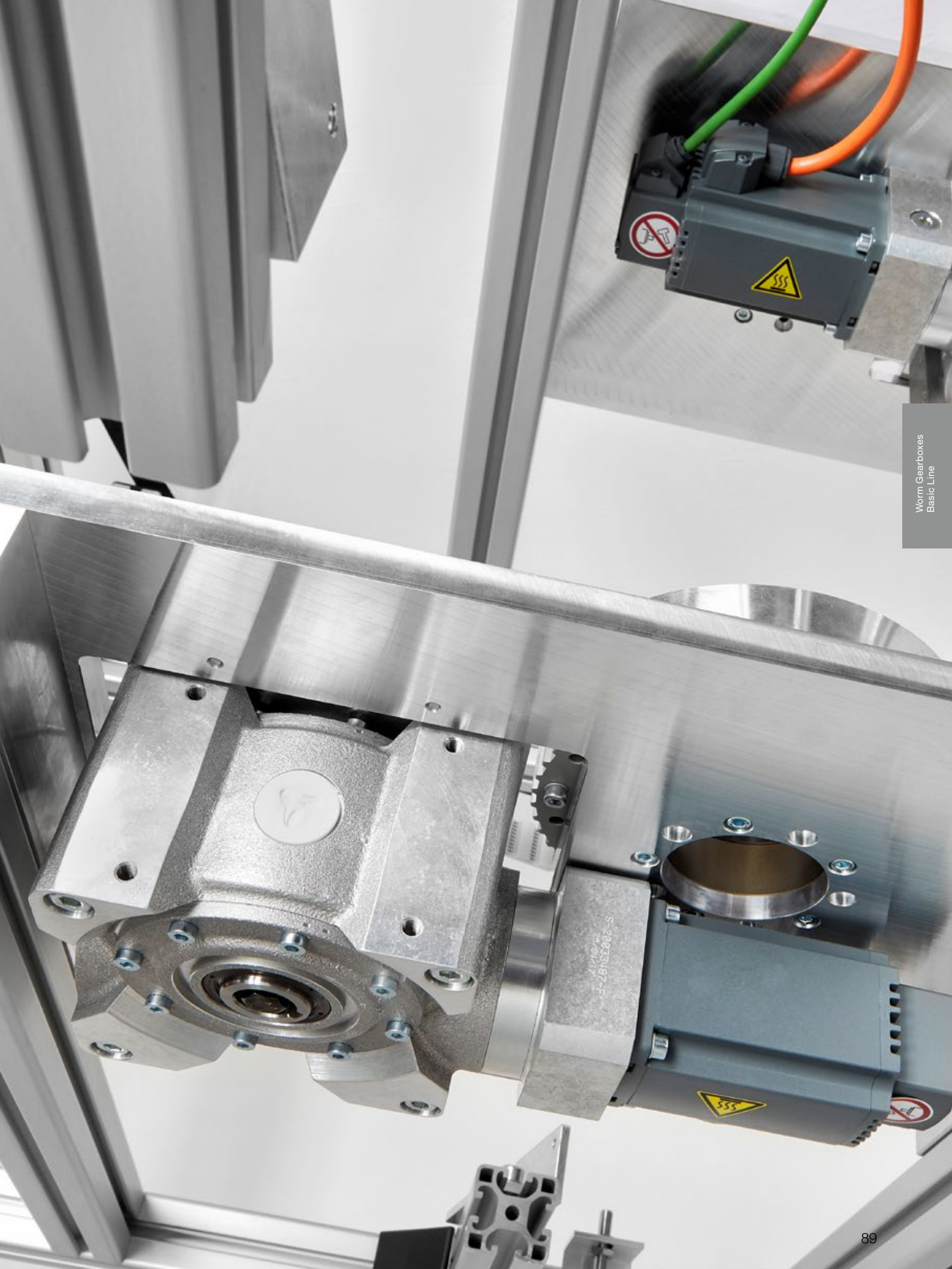

CVH / CVS – We drive the Performance

CVH

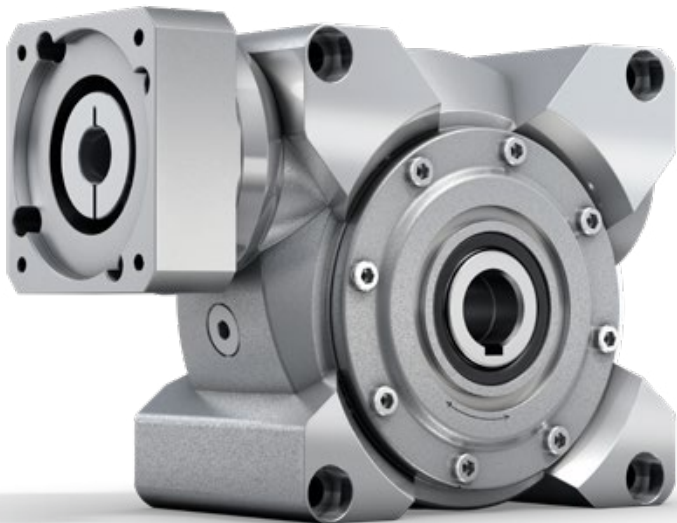

The V-Drive Basic is characterized by a specially developed toothing that minimizes operating noise during S1 operation and offers enormous power. And all with a top price/performance ratio.

PRODUCT HIGHLIGHTS

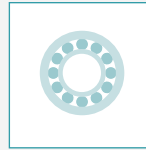

Optimized output bearings

The V-Drive Basic features an optimized output bearing tailored to the most diverse areas of application. For increased requirements for the absorption of external forces, the reinforced bearing option is used.



Specially developed toothing

The operating noise during S1 operation has been minimized by means of a specially developed toothing featuring high torques, good synchronization, and very low operating noise.



Top price/performance ratio

A top price/performance ratio is achieved with short delivery times and “made in Germany” quality.

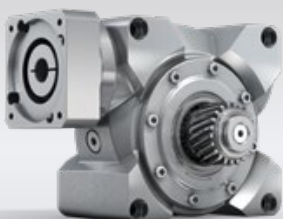

CVS – worm gearbox with pinion

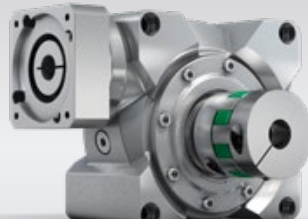

CVS – worm gearbox with elastomer coupling



SIZING ASSISTANT
YOUR GEARBOX WITHIN SECONDS

Efficient gearbox sizing within seconds –
online without login
www.sizing-assistant.com

CVS

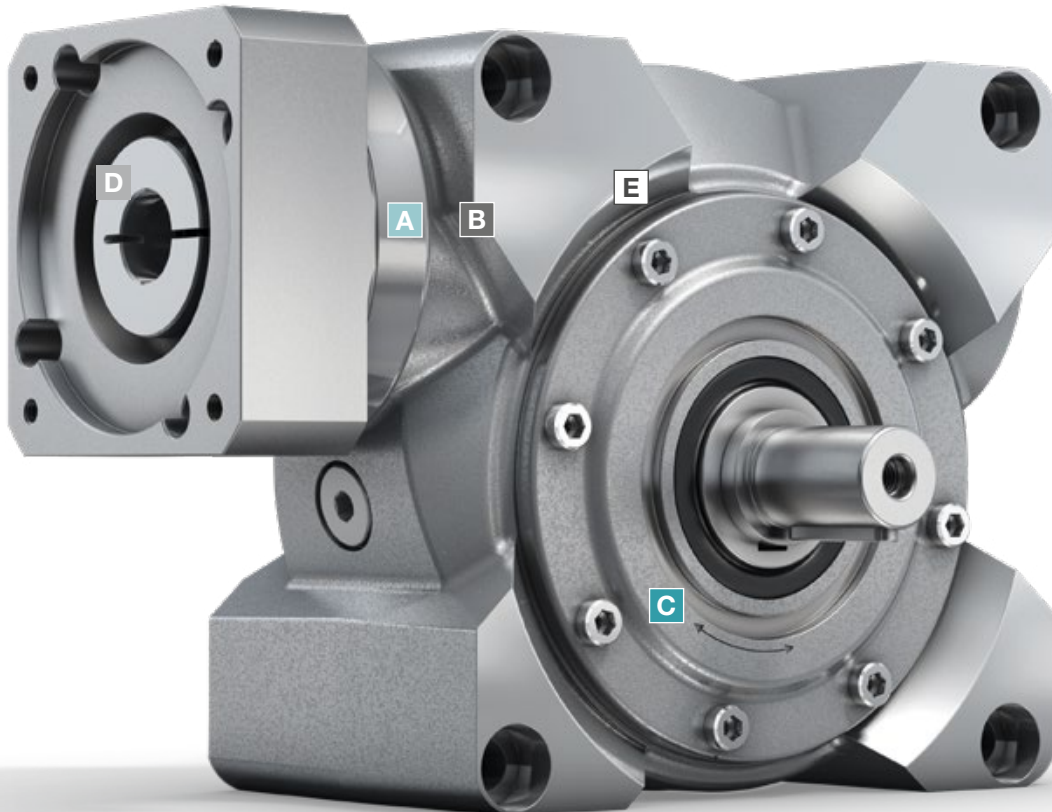

- A Radial shaft seal**
- Very long service life
 - Optimized for continuous operation

- B Input bearing**
- Bearing package to absorb axial and radial forces
 - Very well suited to high input speeds

- C Output bearing**
- Tailored to the most diverse areas of application

- D Metal bellows coupling**
- Completely backlash free
 - Lifetime durable and maintenance free
 - Easy assembly
 - Protects the motor through thermal linear expansion compensation

- E Toothing**
- Specially developed toothing, for high torques, good synchronization, and low operating noise

CVH 040 MF 1-stage

			1-stage						
Ratio	i		7	10	16	28	40		
Max. torque ^{a) b)} (at $n_1 = 500$ rpm)	T_{2a}	Nm	68	76	78	82	76		
		in.lb	602	673	690	726	673		
Emergency stop torque ^{a) b)} (permitted 1000 times during the service life of the gearbox)	T_{2Not}	Nm	126	125	129	134	122		
		in.lb	1115	1106	1142	1186	1080		
Permitted average input speed ^{d)} (at 20 °C ambient temperature)	n_{1N}	rpm	4000						
Max. input speed	n_{1Max}	rpm	6000						
Mean no load running torque ^{b)} (at $n_1 = 3000$ rpm and 20 °C gearbox temperature)	T_{012}	Nm	0.7	0.6	0.5	0.4	0.4		
		in.lb	6.2	5.3	4.4	3.5	3.5		
Max. backlash	j_t	arcmin	≤ 15						
Torsional rigidity ^{b)}	C_{t21}	Nm/arcmin	3.5	3.5	3.5	3.5	3.5		
		in.lb/arcmin	31	31	31	31	31		
Max. axial force ^{c)} (Standard / HIGH FORCES)	F_{2AMax}	N	1200 / 3000						
		lb _f	270 / 675						
Max. lateral force ^{b)} (Standard / HIGH FORCES)	F_{2OMax}	N	1000 / 2400						
		lb _f	225 / 540						
Max. tilting moment (Standard / HIGH FORCES)	M_{2KMax}	Nm	97 / 205						
		in.lb	858 / 1814						
Efficiency at full load (at $n_1 = 500$ rpm)	η	%	89	87	81	72	66		
Service life	L_n	h	> 15000						
Weight (incl. standard adapter plate)	m	kg	4.5						
		lb _m	10						
Operating noise (at reference ratio and reference speed – ratio-specific values available in cymex [®])	L_{PA}	dB(A)	≤ 54						
Max. permitted housing temperature		°C	+90						
		°F	+194						
Ambient temperature		°C	-15 to +40						
		°F	+5 to +104						
Lubrication			Lubricated for life						
Direction of rotation			See drawing						
Protection class			IP 65						
Shrink disc (Standard Version)			SD 024x050 S2						
Max. torque (without axial force)	T_{max}	Nm	250						
		in.lb	2213						
Mass moment of inertia (relates to the drive) Clamping hub diameter [mm]	C	14	J_1	kgcm ²	0.38	0.38	0.34	0.32	0.31
				10 ⁻³ in.lb.s ²	0.34	0.34	0.30	0.28	0.27
	E	19	J_1	kgcm ²	0.40	0.37	0.35	0.34	0.33
				10 ⁻³ in.lb.s ²	0.35	0.33	0.31	0.30	0.29

Please use our sizing software cymex[®] for a detailed sizing – www.wittenstein-cymex.com

^{a)} At max. 10 % F_{2OMax}

^{b)} Valid for standard clamping hub diameter

^{c)} Refers to center of the output shaft or flange

^{d)} Please reduce input speed at higher ambient temperatures

Motor shaft diameter [mm]

1-stage

up to 14/19⁴⁾ (C⁶⁾/E)
clamping hub diameter

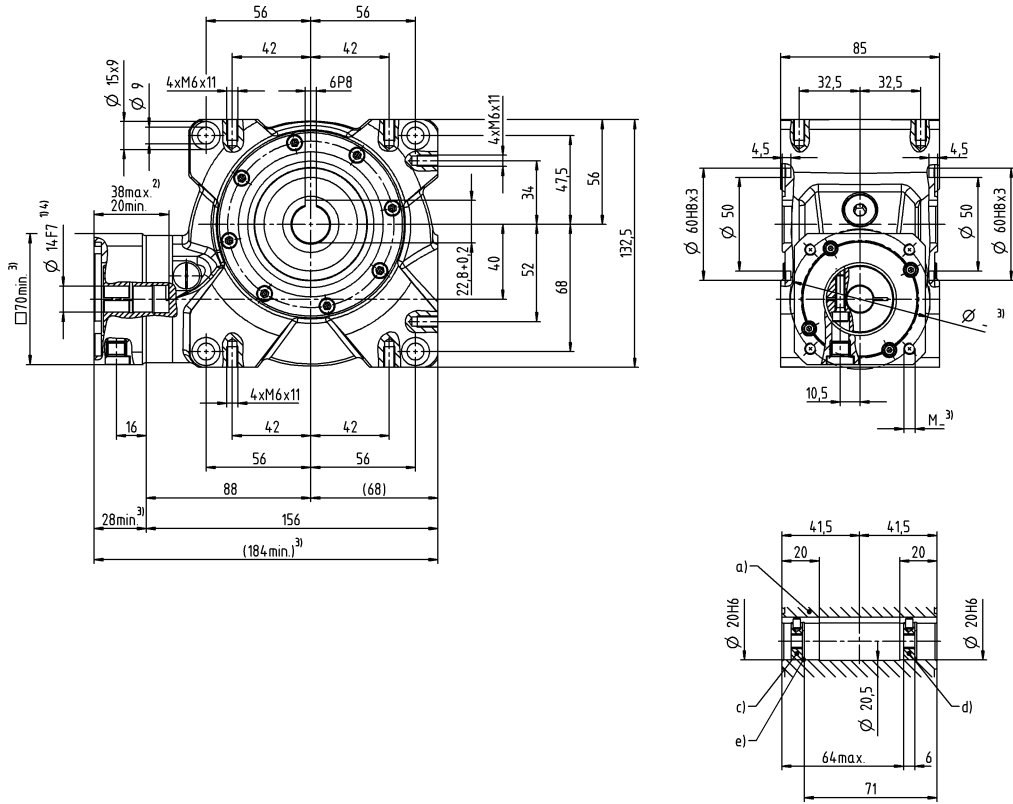

Worm Gearboxes
Basic Line

Other output variants

Hollow shaft interfaces on both sides

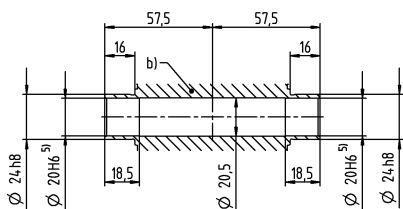

- a) Hollow shaft, keyed on both sides
- b) Hollow shaft interfaces on both sides
- c) End disc for screw M6 (on request)
- d) End disc as forcing washer for screw M8 (on request)
- e) Locking ring – DIN 472 (on request)

See technical data sheet for available clamping hub diameters (mass moment of inertia). Dimensions available on request.

Non-tolerated dimensions are nominal dimensions

- ¹⁾ Check motor shaft fit
- ²⁾ Min./Max. permissible motor shaft length
Longer motor shafts are adaptable, please contact us
- ³⁾ The dimensions depend on the motor
- ⁴⁾ Smaller motor shaft diameter is compensated by a bushing with a minimum thickness of 1 mm
- ⁵⁾ Tolerance h6 for mounted shaft
- ⁶⁾ Standard clamping hub diameter

CVH 050 MF 1-stage

			1-stage					
Ratio	<i>i</i>		7	10	16	28	40	
Max. torque ^{a) b)} (at $n_1 = 500$ rpm)	T_{2a}	Nm	125	127	131	140	116	
		in.lb	1106	1124	1159	1239	1027	
Emergency stop torque ^{a) b)} (permitted 1000 times during the service life of the gearbox)	T_{2Not}	Nm	242	242	250	262	236	
		in.lb	2142	2142	2213	2319	2089	
Permitted average input speed ^{d)} (at 20 °C ambient temperature)	n_{1N}	rpm	4000					
Max. input speed	n_{1Max}	rpm	6000					
Mean no load running torque ^{b)} (at $n_1 = 3000$ rpm and 20 °C gearbox temperature)	T_{012}	Nm	2.2	1.6	1.5	1.2	1.1	
		in.lb	19.5	14.2	13.3	10.6	9.7	
Max. backlash	j_t	arcmin	≤ 15					
Torsional rigidity ^{b)}	C_{t21}	Nm/arcmin	5.5	5.5	5.5	5.5	5.5	
		in.lb/arcmin	49	49	49	49	49	
Max. axial force ^{c)} (Standard / HIGH FORCES)	F_{2AMax}	N	1500 / 5000					
		lb _f	337.5 / 1125					
Max. lateral force ^{b)} (Standard / HIGH FORCES)	F_{2OMax}	N	1200 / 3800					
		lb _f	270 / 855					
Max. tilting moment (Standard / HIGH FORCES)	M_{2KMMax}	Nm	130 / 409					
		in.lb	1150 / 3620					
Efficiency at full load (at $n_1 = 500$ rpm)	η	%	89	85	80	70	63	
Service life	L_h	h	> 15000					
Weight (incl. standard adapter plate)	m	kg	8					
		lb _m	18					
Operating noise (at reference ratio and reference speed – ratio-specific values available in cymex [®])	L_{PA}	dB(A)	≤ 62					
Max. permitted housing temperature		°C	+90					
		°F	+194					
Ambient temperature		°C	-15 to +40					
		°F	+5 to +104					
Lubrication			Lubricated for life					
Direction of rotation			See drawing					
Protection class			IP 65					
Shrink disc (Standard Version)			SD 030x060 S2V					
Max. torque (without axial force)	T_{max}	Nm	550					
		in.lb	4868					
Mass moment of inertia (relates to the drive) Clamping hub diameter [mm]	E 19	J_1	kgcm ²	1.22	1.17	1.06	1.05	1.01
			10 ⁻³ in.lb.s ²	1.08	1.04	0.94	0.93	0.89

Please use our sizing software cymex[®] for a detailed sizing – www.wittenstein-cymex.com

^{a)} At max. 10 % F_{2OMax}

^{b)} Valid for standard clamping hub diameter

^{c)} Refers to center of the output shaft or flange

^{d)} Please reduce input speed at higher ambient temperatures

Motor shaft diameter [mm]

1-stage

up to 19⁴⁾ (E⁶⁾
clamping hub diameter

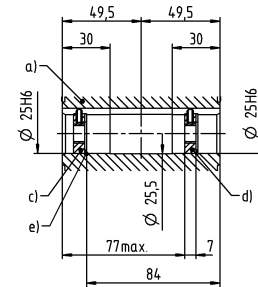
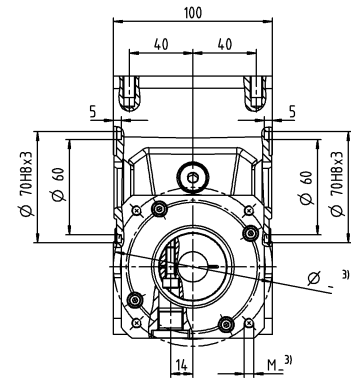
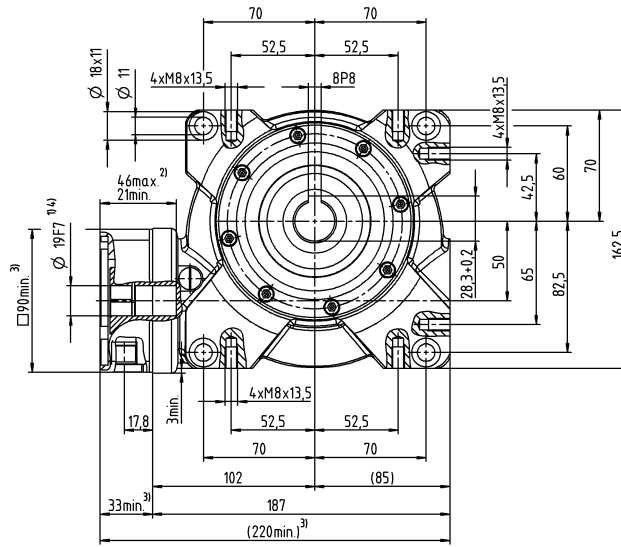

Other output variants

Hollow shaft interfaces on both sides

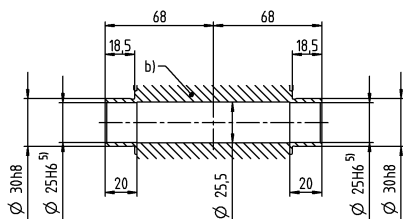

- a) Hollow shaft, keyed on both sides
- b) Hollow shaft interfaces on both sides
- c) End disc for screw M10 (on request)
- d) End disc as forcing washer for screw M12 (on request)
- e) Locking ring – DIN 472 (on request)

See technical data sheet for available clamping hub diameters (mass moment of inertia). Dimensions available on request.

Non-tolerated dimensions are nominal dimensions

- ¹⁾ Check motor shaft fit
- ²⁾ Min./Max. permissible motor shaft length
Longer motor shafts are adaptable, please contact us
- ³⁾ The dimensions depend on the motor
- ⁴⁾ Smaller motor shaft diameter is compensated by a bushing with a minimum thickness of 1 mm
- ⁵⁾ Tolerance h6 for mounted shaft
- ⁶⁾ Standard clamping hub diameter

CVH 063 MF 1-stage

			1-stage					
Ratio	i		7	10	16	28	40	
Max. torque ^{a) b)} (at $n_1 = 500$ rpm)	T_{2a}	Nm	265	270	280	301	282	
		in.lb	2345	2390	2478	2664	2496	
Emergency stop torque ^{a) b)} (permitted 1000 times during the service life of the gearbox)	T_{2Not}	Nm	484	491	494	518	447	
		in.lb	4283	4345	4372	4584	3956	
Permitted average input speed ^{d)} (at 20 °C ambient temperature)	n_{1N}	rpm	4000					
Max. input speed	n_{1Max}	rpm	4500					
Mean no load running torque ^{b)} (at $n_1 = 3000$ rpm and 20 °C gearbox temperature)	T_{012}	Nm	3.1	3	2.4	2.3	2.2	
		in.lb	27.4	26.6	21.2	20.4	19.5	
Max. backlash	j_t	arcmin	≤ 15					
Torsional rigidity ^{b)}	C_{t21}	Nm/arcmin	23	23	23	23	23	
		in.lb/arcmin	204	204	204	204	204	
Max. axial force ^{c)} (Standard / HIGH FORCES)	F_{2AMax}	N	2000 / 8250					
		lb _f	450 / 1856					
Max. lateral force ^{b)} (Standard / HIGH FORCES)	F_{2OMax}	N	2000 / 6000					
		lb _f	450 / 1350					
Max. tilting moment (Standard / HIGH FORCES)	M_{2KMax}	Nm	281 / 843					
		in.lb	2487 / 7461					
Efficiency at full load (at $n_1 = 500$ rpm)	η	%	90	87	82	73	67	
Service life	L_h	h	> 15000					
Weight (incl. standard adapter plate)	m	kg	13					
		lb _m	29					
Operating noise (at reference ratio and reference speed – ratio-specific values available in cymex [®])	L_{PA}	dB(A)	≤ 64					
Max. permitted housing temperature		°C	+90					
		°F	+194					
Ambient temperature		°C	-15 to +40					
		°F	+5 to +104					
Lubrication			Lubricated for life					
Direction of rotation			See drawing					
Protection class			IP 65					
Shrink disc (Standard Version)			SD 036x072 S2V					
Max. torque (without axial force)	T_{max}	Nm	640					
		in.lb	5664					
Mass moment of inertia (relates to the drive) Clamping hub diameter [mm]	H 28	J_1	kgcm ²	3.75	3.61	3.52	3.48	3.36
			10 ⁻³ in.lb.s ²	3.32	3.19	3.12	3.08	2.97

Please use our sizing software cymex[®] for a detailed sizing – www.wittenstein-cymex.com

^{a)} At max. 10 % F_{2OMax}

^{b)} Valid for standard clamping hub diameter

^{c)} Refers to center of the output shaft or flange

^{d)} Please reduce input speed at higher ambient temperatures

Motor shaft diameter [mm]

1-stage

up to 28⁴⁾ (H)⁶⁾
clamping hub diameter

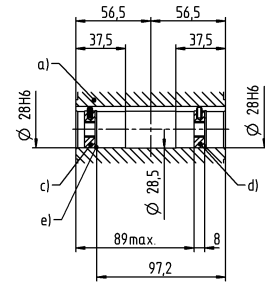
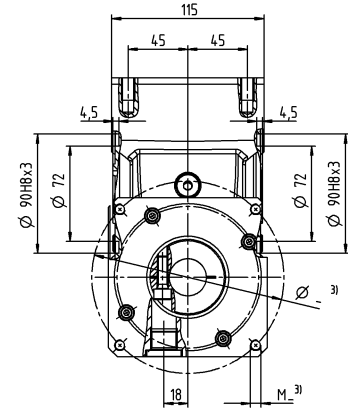
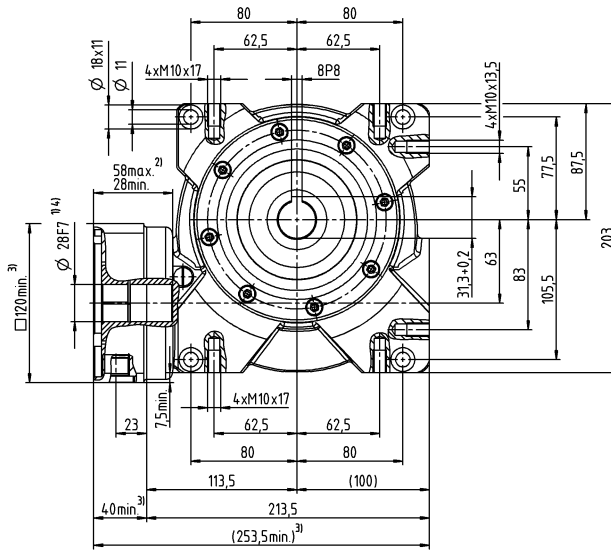

Other output variants

Hollow shaft interfaces on both sides

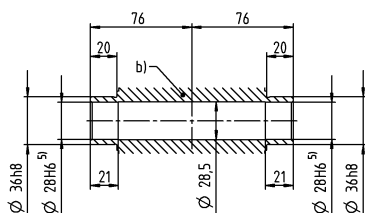

- a) Hollow shaft, keyed on both sides
- b) Hollow shaft interfaces on both sides
- c) End disc for screw M10 (on request)
- d) End disc as forcing washer for screw M12 (on request)
- e) Locking ring – DIN 472 (on request)

See technical data sheet for available clamping hub diameters (mass moment of inertia). Dimensions available on request.

Non-tolerated dimensions are nominal dimensions

- ¹⁾ Check motor shaft fit
- ²⁾ Min./Max. permissible motor shaft length
Longer motor shafts are adaptable, please contact us
- ³⁾ The dimensions depend on the motor
- ⁴⁾ Smaller motor shaft diameter is compensated by a bushing with a minimum thickness of 1 mm
- ⁵⁾ Tolerance h6 for mounted shaft
- ⁶⁾ Standard clamping hub diameter