

ROTARY INDEXING RING

TR0750A / TR1100A / TR1500A / TR2200A

MOUNTING INSTRUCTIONS

TD0026A-EN00-0000-00

062019_4.0_EN

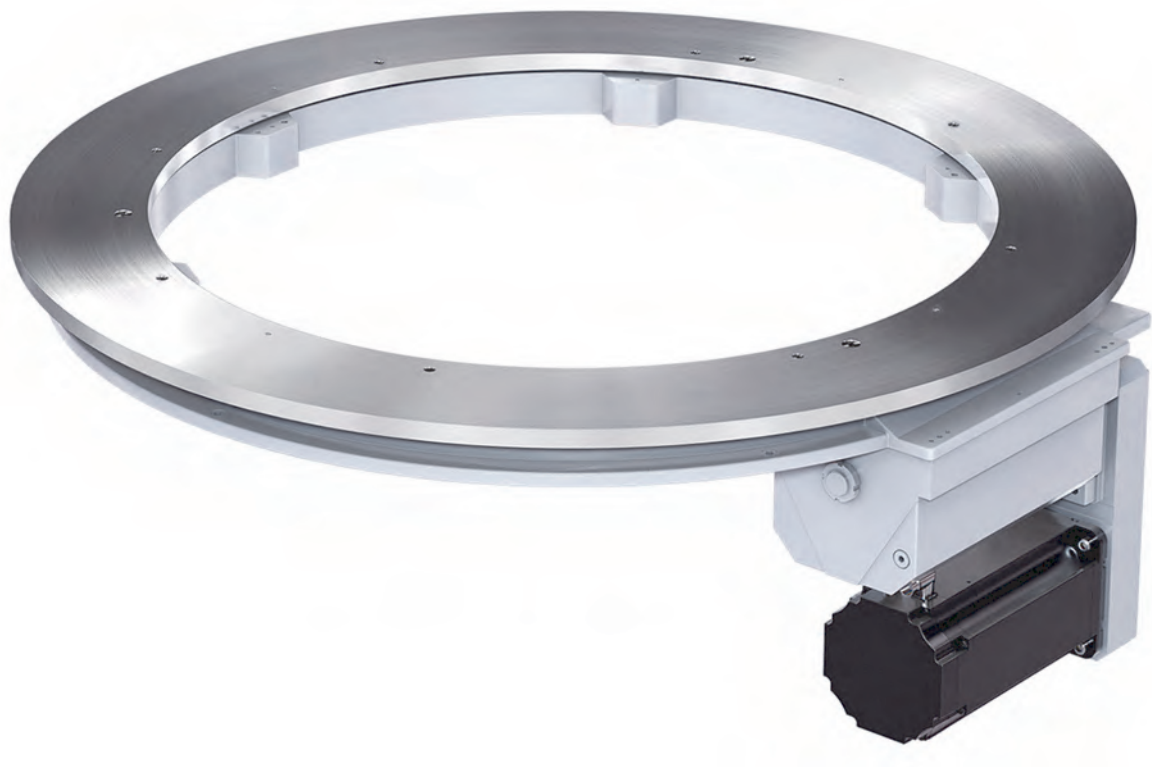

Table of contents

1	Introduction.....	5
1.1	About these mounting instructions.....	5
1.2	Intended use.....	5
1.3	Predictable incorrect application.....	5
1.4	Applicable documents.....	6
1.5	Warranty.....	7
2	Safety.....	8
2.1	Safety messages and hazard categories.....	8
2.2	Hazard symbols.....	8
2.3	Responsibilities of the system integrator and/or operator.....	9
2.4	Qualification of personnel.....	9
3	Product description.....	10
3.1	Overview.....	10
3.2	Function description.....	12
3.3	Nameplate.....	13
3.4	Type code.....	13
3.5	Mounting positions.....	14
3.6	Drive positions.....	15
3.7	Passage of media.....	16
4	Technical data.....	17
4.1	General.....	17
4.2	Motor.....	17
4.3	Holding brake.....	20
4.4	Inductive sensor.....	20
4.5	DRIVE-CLiQ encoder (optional).....	20
4.6	Climatic environmental conditions "Operation".....	21
4.7	Climatic environmental conditions "Transportation and Storage".....	21
4.8	Dimensions.....	22
4.9	Load data.....	26
5	Packaging.....	27
5.1	Types of packaging.....	27
5.2	Unpacking the product.....	27
5.3	Verification of the delivery.....	27
6	Transportation.....	28
6.1	Transporting the product.....	28

6.2	Load lifting and handling equipment.....	29
6.3	Fastening the load lifting and handling equipment.....	29
7	Storage.....	31
7.1	Storing the product.....	31
8	Mounting.....	32
8.1	Prerequisites for mounting.....	32
8.2	Equipment and tools.....	32
8.3	Tightening torques and property classes.....	33
8.4	Bolting down the product.....	33
8.5	Displacing the drive housing.....	34
8.6	Mounting additional components.....	36
8.7	Mounting safety equipment.....	39
9	Electrical connection.....	40
9.1	Connection diagram supply voltage.....	40
10	Controller.....	42
10.1	Basic information on control.....	42
10.2	External controller (PLC).....	43
11	Commissioning.....	45
11.1	Prerequisites for commissioning.....	45
11.2	Performing commissioning.....	45
12	Operation.....	47
12.1	Basic information on operation.....	47
13	Troubleshooting.....	48
13.1	Issue, cause and remedy.....	48
14	Cleaning.....	50
14.1	Performing cleaning.....	50
15	Maintenance.....	52
15.1	Maintenance plan.....	52
15.2	Lubricant.....	52
15.3	Replacing the motor.....	52
15.4	Inspecting the toothed belt.....	57
15.5	Replacing the toothed belt.....	59
15.6	Inspecting the holding brake.....	62
15.7	Readjusting the air gap of the holding brake.....	64
15.8	Replacing the holding brake.....	67
15.9	Replacing the inductive sensor.....	72



16	Decommissioning	76
16.1	Decommissioning the product.....	76
17	Dismounting	76
17.1	Dismounting the product.....	76
18	Disposal	76
18.1	Disposing of the product.....	76
19	Service and spare parts	77
19.1	Worldwide service.....	77
19.2	Ordering spare parts.....	78

1 Introduction

1.1 About these mounting instructions

These mounting instructions describe the product "Rotary indexing ring TR0750A / TR1100A / TR1500A / TR2200A" (also referred to as "product" in this document).

These mounting instructions are part of the product.

- You may only use the product if you have fully read and understood these mounting instructions.
- Verify that these mounting instructions are always accessible for any type of work performed on or with the product.
- Pass these mounting instructions as well as all other product-related documents on to all owners of the product.
- If you feel that these mounting instructions contain errors, inconsistencies, ambiguities or other issues, contact the manufacturer prior to using the product.

These mounting instructions are protected by copyright and may only be used as provided for by the corresponding copyright legislation. We reserve the right to modifications.

The manufacturer shall not be liable in any form whatsoever for direct or consequential damage resulting from failure to observe these mounting instructions or from failure to comply with directives, regulations and standards and any other statutory requirements applicable at the installation site of the product.

1.2 Intended use

The product is a partly complete machine pursuant to Directive 2006/42/EU, articles 1g and 2g. The product is only intended to be incorporated into or assembled with other machinery or other partly completed machinery or equipment, thereby forming machinery to which Directive 2006/42/EU applies.

The product may only be used within the limits specified in these mounting instructions and in the applicable documents. The applicable documents are also part of the product.

The machinery must not be put into service until the machinery into which the product has been incorporated has been determined and declared in conformity with the provisions of Directive 2006/42/EU and with all other applicable directives and regulations.

In addition, perform a risk assessment in view of the planned application, according to an approved risk assessment method, and implement the appropriate safety measures, based on the results of the risk assessment. Take into account the consequences of installing or integrating the product into a system or a plant.

When using the product, perform all work and all other activities in conjunction with the product in compliance with the conditions specified in the mounting instructions, in the applicable documents, and on the nameplate, as well as with all directives, standards, and safety regulations applicable at the installation site of the product.

1.3 Predictable incorrect application

Any use of the product beyond the explicitly indicated intended use is an impermissible, incorrect application of the product.

The product must never be used in the following cases, under the following conditions, and for the following purposes:

- Operation in residential environments
- Operation in life-supporting systems
- Operation in potentially explosive atmospheres/hazardous areas
- Operation on ships, in rail vehicles, land craft or in aircraft
- Operation in military facilities
- Operation outside of the specified order data
- Applications involving transportation of persons (fairground rides)

1.4 Applicable documents

In addition to these mounting instructions, the following documents are binding for and apply to any type of use of the product:

- Order data (including, but not limited to, design data, load data, performance data, transportation and storage instructions, information attached to the product and the package, as well as other specifications).
- Documentations of the manufacturers of all products belonging to the scope of delivery (for example, motor, accessories, attachment parts). This includes, among other things:

Type of manual	Type	Manufacturer	Delivery	
			Paper format	Electronic
Operating and maintenance instructions	Motor IEC low voltage squirrel cage asynchronous motors enclosed version	Končar – MES d.d.	-	X
Data sheet	Inductive sensor PNP, NBB2-8GM40-E2-V3	Pepperl+Fuchs-Gruppe	-	X
Data sheet	Inductive sensor PNP, NBB4-12GM30-E2-V1	Pepperl+Fuchs-Gruppe	-	X
Data sheet	Inductive sensor NPN, NBB4-12GM30-E0-V1	Pepperl+Fuchs-Gruppe	-	X
Data sheet	Inductive sensor NPN, 3RG4011-7GB33-PF	Pepperl+Fuchs-Gruppe	-	X
Data sheet	DRIVE-CliQ encoder 6FX2001-5FD25-1AA0	SIEMENS AG	-	X
Safety data sheet	Lubricant Shell Omala S2 G 680	Shell Deutschland Oil GmbH	-	X
Safety data sheet	Lubricant Shell Gadus S2 V220AD 2	Shell Deutschland Oil GmbH	-	X



In the case of delivery with WEISS GmbH controller/software package:			Delivery	
			Paper format	Electronic
Electrical documenta- tion	List of applicable documents, per product (see documents on the CD delivered with the product)	WEISS GmbH	-	X

1.5 Warranty

See our website for our General Terms and Conditions at www.weiss-international.com or your purchase order.

2 Safety

2.1 Safety messages and hazard categories

These mounting instructions contain safety messages to alert you to potential hazards and risks. Safety messages in these mounting instructions are highlighted with warning symbols and warning words.

The signal word describes the source of the hazard. The text contains instructions on how to avoid the hazard as well as the consequence resulting from failure to follow the instructions given in the safety message.

Depending on the severity of a hazard, the safety messages are classified according to different hazard categories.



DANGER

DANGER indicates an immediately hazardous situation, which, if not avoided, will result in death or serious injury.



WARNING

WARNING indicates a hazardous situation, which, if not avoided, can result in death or serious injury or equipment damage.



CAUTION

CAUTION indicates a hazardous situation, which, if not avoided, can result in injury or equipment damage.

NOTICE

NOTICE indicates a hazardous situation, which, if not avoided, can result in equipment damage.

In addition to the instructions and safety messages provided in these mounting instructions, you must comply with all directives, standards, and safety regulations applicable at the installation site of the product.

2.2 Hazard symbols

The following symbols are used in these mounting instructions:



This is the general safety alert symbol. It alerts to injury hazards or equipment damage. Comply with all safety instructions in conjunction with this symbol to help avoid possible death, injury, or equipment damage.



This symbol alerts to hazardous electrical voltage. If this symbol is used in a safety message, there is a hazard of electric shock.

Hazard symbols may also be attached to the product.



Hazard of hot surface



Hazard of magnetic field



No access for persons with heart pacemakers or other medical implants

2.3 Responsibilities of the system integrator and/or operator

The system integrator (the person who incorporates the product in a machine pursuant to Directive 2006/42/EU, i.e., for example, the machine builder) and/or the operator must ensure the following:

- The application and use of the product must be limited to the specified intended use.
- In the integration of the product, all functional safety requirements must be met.
- All directives, standards, and safety regulations, including all regulations concerning workplace safety and prevention of accidents, applicable at the installation site of the product must be complied with.
- Any type of work whatsoever on and with the product may only be performed by qualified personnel.
- The product may only be operated when it is in flawless, fully functional condition.
- All safety equipment must operate as required and planned.
- The personal protective equipment for the personnel/operator must be available and must be used.
- The mounting instructions and all applicable documents must always be accessible in their entirety to the personnel at the installation site of the product.
- Safety instructions, labels, and any other information attached to the product must not be removed.
- A complete manual must be available for the machine into which the product is incorporated; this manual must describe all types of work on and with the machine and contain all information relevant with regard to the product.

If the system integrator himself is not in the position to comply with any of these obligations, the system integrator must impose compliance with these obligations on the operator.

2.4 Qualification of personnel

Only trained personnel who have fully read and understood the mounting instructions and all applicable documents for the product may perform work on and with the product.

This trained personnel must have sufficient technical training, knowledge, and experience, and be able to foresee and detect potential hazards that may be caused by using the product.

All trained personnel working on and with the product must be fully familiar with all directives, standards, and safety regulations that must be observed for performing such work.

3 Product description

3.1 Overview

Product type: TR0750A

The product consists of the following components:

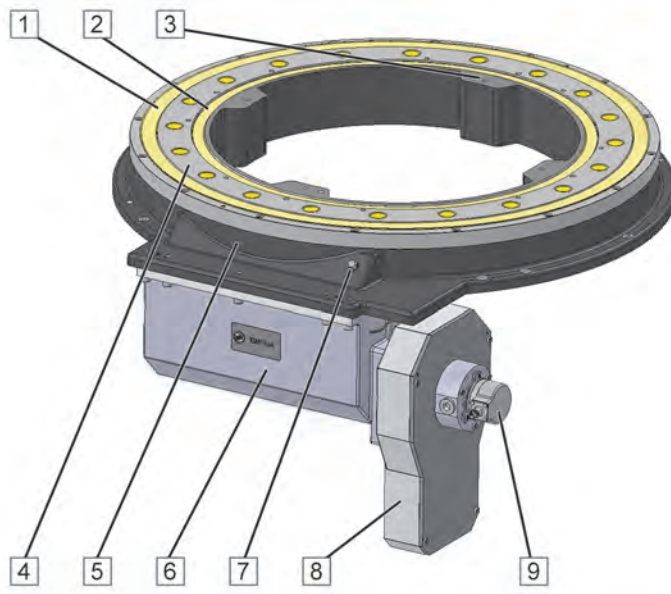

- | | | | |
|----------|----------------------------------|----------|--------------------|
| 1 | Shaft sealing ring | 6 | Cam housing |
| 2 | Shaft sealing ring | 7 | Vent screw |
| 3 | Mounting surface for raised ring | 8 | Drive housing |
| 4 | Output flange | 9 | Encoder (optional) |
| 5 | Housing | | |

Product description

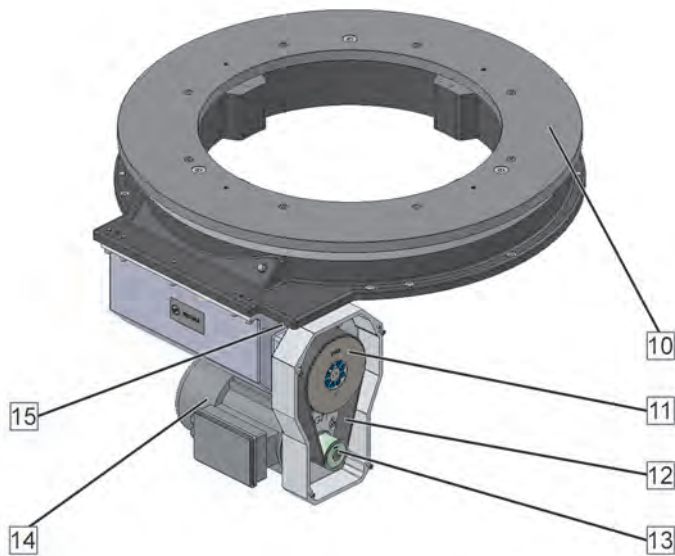

- | | | | |
|-----------|-----------------------------------|-----------|-----------------------------|
| 10 | Rotating ring (customer-specific) | 13 | Toothed belt pulley (motor) |
| 11 | Toothed belt pulley (gear) | 14 | Motor |
| 12 | Toothed belt | 15 | Inductive sensor |

Product type: TR1100A/TR1500A/TR2200A

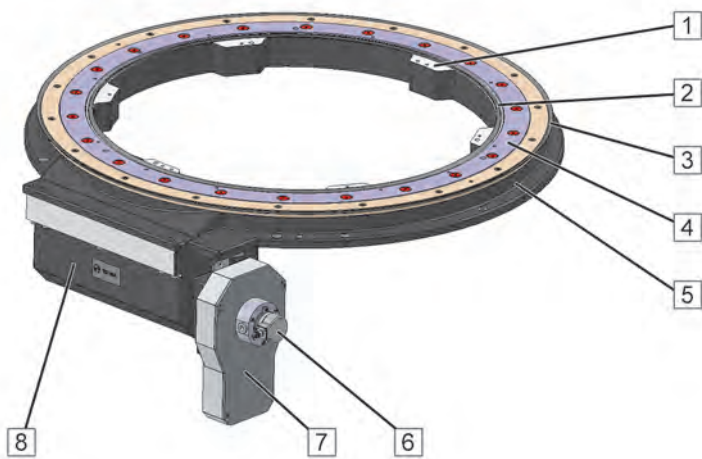

- | | | | |
|----------|----------------------------------|----------|--------------------|
| 1 | Mounting surface for raised ring | 5 | Housing |
| 2 | Profile seal | 6 | Encoder (optional) |
| 3 | Profile seal | 7 | Drive housing |
| 4 | Output flange | 8 | Cam housing |

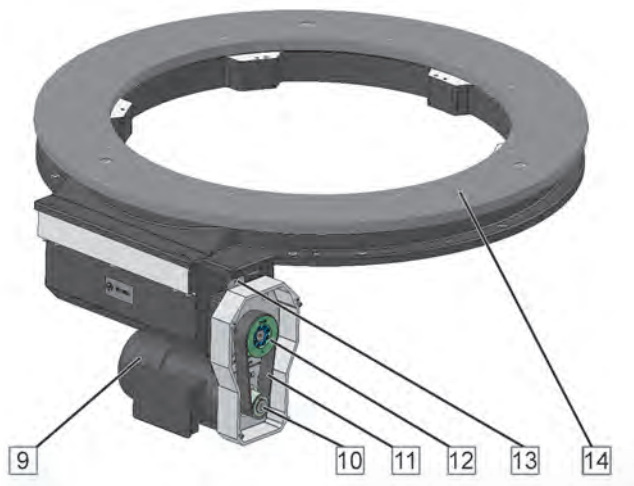

- | | | | |
|-----------|-----------------------------|-----------|-----------------------------------|
| 9 | Motor | 12 | Toothed belt pulley (gear) |
| 10 | Toothed belt pulley (motor) | 13 | Inductive sensor |
| 11 | Toothed belt | 14 | Rotating ring (customer-specific) |

3.2 Function description

The product moves payloads to predetermined positions via cycled rotary movements. A three-phase motor with a holding brake drives a cam mechanism. Defined acceleration and deceleration allow for soft start and stop of the rotary movements.

The motor drives a toothed belt, a single-stage or dual-stage gear and the driving cam. The motor is switched off when the output flange has reached one of the possible positions. The electromechanical holding brake is released by applying the brake voltage.

During the rotation phase, the cam rollers (with needle bearings) follow the curved path of the driving cam. When the output flange is at a standstill, two pre-tensioned cam rollers are in contact with the driving cam. The position of a position cam on the driving cam is detected by an inductive sensor. If the inductive sensor is active, the output flange is in one of the possible positions. In this state, a corresponding signal is available to the controller.

3.3 Nameplate

The nameplate is attached to the housing of the product; it contains the following information:



Figure 1: Example of nameplate

- | | | | |
|---|----------------|---|-------------------------|
| 1 | Type | 5 | Year of manufacture |
| 2 | Serial number | 6 | Weight |
| 3 | Indexing stops | 7 | QR code company website |
| 4 | Velocity stage | 8 | DM code serial number |

The scope of delivery contains a second nameplate. If the factory-mounted nameplate is covered by attachments, the second nameplate can be attached at a readily visible position of the product or machine for identification of the product.

3.4 Type code

Structure of the type code:

Type	Size	Version	Encoder	Gear stage	Motor
TR	0750 1100 1500 2200	A	-	-	-

3.5 Mounting positions

NOTICE

OIL LOSS OR DRY RUN DUE TO INCORRECT MOUNTING POSITION

Failure to follow these instructions can result in equipment damage.

- Verify that you only use the standard mounting positions approved in these mounting instructions.

Permissible standard mounting positions

The product may only be mounted as shown below.

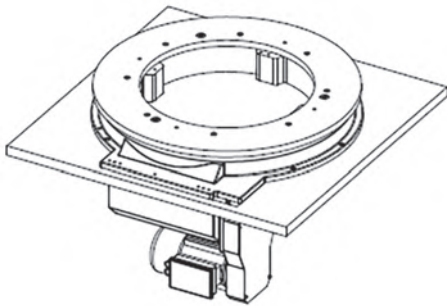

The product types TR0750A, TR1100A, TR1500A and TR2200A may only be mounted horizontally.
Normal / MP 1

3.6 Drive positions

The product is delivered with the drive position specified in the order.

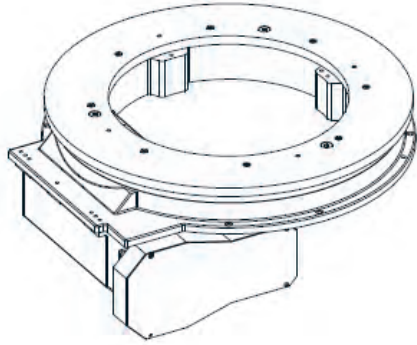

Drive housing at the inside / DP 1

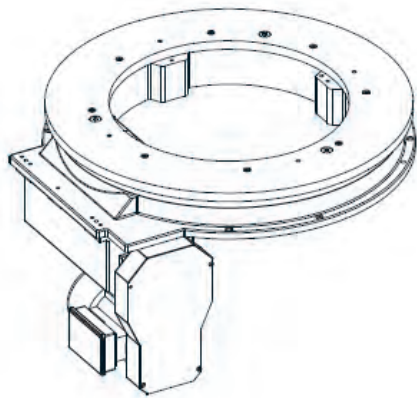

Drive housing at the bottom / DP 2

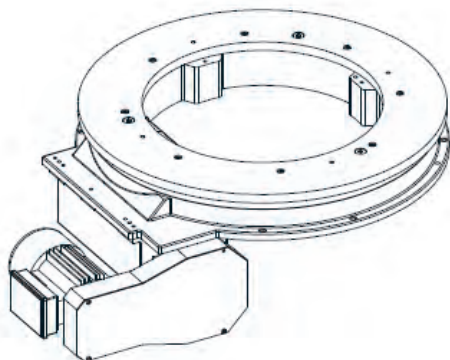

Drive housing at the outside / DP 3

3.7 Passage of media

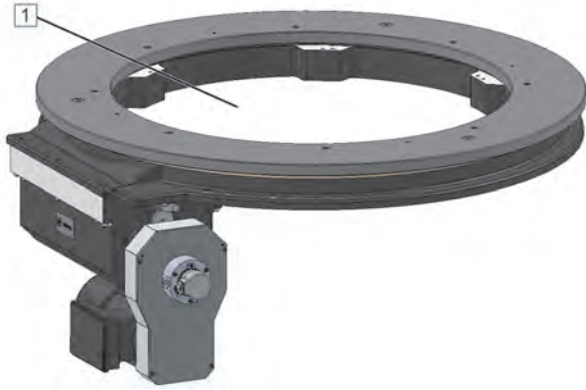

The inner opening [1] can be used for the passage of media.

4 Technical data

4.1 General

Characteristic	Unit	Value			
		TR0750A	TR1100A	TR1500A	TR2200A
Direction of rotation	-	Left, right, or alternating			
Recommended maximum diameter of attachment	mm	Approximately 1500	Approximately 2200	Approximately 3000	Approximately 4400
Indexing accuracy	arcsec	36 (± 18)	36 (± 18)	30 (± 15)	24 (± 12)
Maximum axial runout of output flange	mm	at Ø 635 0.05	at Ø 945 0.06	at Ø 1275 0.08	at Ø 1990 0.08
Maximum axial runout including the rotary ring	mm	at Ø 750 0.07	at Ø 1100	at Ø 1500 0.1	at Ø 2200 0.15
Maximum radial runout of the output flange	mm	0.03	0.04	0.04	0.05
Maximum error in parallelism between output flange and mounting surface of housing	mm	0.05	0.06	0.08	0.08
Weight (without rotary ring)	kg	230	310	400	950
Weight with packaging	kg	See bill of delivery			
Sound pressure	dB(A)	< 70			
Lubricant	-	Shell Omala S2 G 680			
Lubricant volume	l	2	2.8	3	5.2

The specified axial and radial runout tolerances are only reached with precise support surfaces.

4.2 Motor

Refer to the documentation of the manufacturer for the technical data of the motor; see applicable documents.

Characteristic	Unit	Value			
		TR0750A	TR1100A	TR1500A	TR2200A
Voltage	V	230 / 400			
Frequency	Hz	50			

Product type	Type	Manufacturer
TR0750A	071L/4 B14 P105 0.37 kW BRE024V 10Nm Thermoklick	Končar – MES d.d.
	071L/4 B14 F105 0.37 kW BRE230V 10Nm Thermoklick	
	071L/6 B14 P105 0.25 kW BRE024V 10Nm Thermoklick	
	071L/6 B14 F105 0.25 kW BRE230V 10Nm Thermoklick	

Product type	Type	Manufacturer
	071L/8 B14 F105 0.18 kW BRE024V 10Nm Thermoklick	
	071L/8 B14 F105 0.18 kW BRE230V 10Nm Thermoklick	
	080L/4 B14 P120 0.75 kW BRE024V 10Nm Thermoklick	
	080L/4 B14 F120 0.75 kW BRE230V 10Nm Thermoklick	
	080S/4 B14 F120 0.55 kW BRE024V 10Nm Thermoklick	
	080S/4 B14 F120 0.55 kW BRE230V 10Nm Thermoklick	
	080L/6 B14 P120 0.55 kW BRE024V 10Nm Thermoklick	
	080L/6 B14 F120 0.55 kW BRE230V 10Nm Thermoklick	
	071S/4 B14 F105 0.25 kW BRE024V 10Nm Thermoklick	
	080V/4 B14 F120 1.10 kW BRE024V Thermoklick	
	080V/4 B14 F120 1.10 kW BRE230V	
	080V/6 B14 P120 0.75 kW BRE024V Thermoklick	
	080V/6 B14 P120 0.75 kW BRE230V	
	TR1100A	
080L/4 B14 F120 0.75 kW BRE230V 10Nm Thermoklick		
080L/6 B14 P120 0.55 kW BRE024V 10Nm Thermoklick		
080L/6 B14 F120 0.55 kW BRE230V 10Nm Thermoklick		
080L/8 B14 P120 0.37 kW BRE024V 10Nm Thermoklick		
080L/8 B14 F120 0.37 kW BRE230V 10Nm Thermoklick		
071L/4 B14 P105 0.37 kW BRE024V 10Nm Thermoklick		
071L/4 B14 F105 0.37 kW BRE230V 10Nm Thermoklick		
071S/4 B14 F105 0.25 kW BRE024V 10Nm Thermoklick		
071L/6 B14 P105 0.25 kW BRE024V 10Nm Thermoklick		
071L/6 B14 F105 0.25 kW BRE230V 10Nm Thermoklick		
071L/8 B14 F105 0.18 kW BRE024V 10Nm Thermoklick		
071L/8 B14 F105 0.18 kW BRE230V 10Nm Thermoklick		
080V/4 B14 F120 1.10 kW BRE024V Thermoklick		
080V/4 B14 F120 1.10 kW BRE230V		
080V/6 B14 P120 0.75 kW BRE024V Thermoklick		
080V/6 B14 P120 0.75 kW BRE230V		
071V/4 B14 P105 0.55 kW BRE024V Thermoklick		
071V/4 B14 P105 0.55 kW BRE230V Thermoklick		
080S/4 B14 F120 0.55 kW BRE024V 10Nm Thermoklick		
080S/4 B14 F120 0.55 kW BRE230V 10Nm Thermoklick		



Product type	Type	Manufacturer
TR1500A	080L/4 B14 P120 0.75 kW BRE024V 10Nm Thermoklick	
	080L/4 B14 F120 0.75 kW BRE230V 10Nm Thermoklick	
	080L/6 B14 P120 0.55 kW BRE024V 10Nm Thermoklick	
	080L/6 B14 F120 0.55 kW BRE230V 10Nm Thermoklick	
	090L/6 B14 F140 1.10 kW BRE024V 20 Nm Thermoklick	
	090L/6 B14 F140 1.10 kW BRE230V 20 Nm Thermoklick	
	080L/8 B14 P120 0.37 kW BRE024V 10Nm Thermoklick	
	080L/8 B14 F120 0.37 kW BRE230V 10Nm Thermoklick	
	090L/8 B14 F140 0.55 kW BRE024V 20 Nm Thermoklick	
	090L/8 B14 F140 0.55 kW BRE230V 20 Nm Thermoklick	
	071L/6 B14 P105 0.25 kW BRE024V 10Nm Thermoklick	
	071L/6 B14 F105 0.25 kW BRE230V 10Nm Thermoklick	
	071L/8 B14 F105 0.18 kW BRE024V 10Nm Thermoklick	
	071L/8 B14 F105 0.18 kW BRE230V 10Nm Thermoklick	
	090L/4 B14 P140 1.50 kW BRE024V 20 Nm Thermoklick	
	090L/4 B14 P140 1.50 kW BRE230V 20 Nm Thermoklick	
	090V/4 B14 P140 2.20 kW BRE024V Thermoklick	
	090V/8 B14 F140 0.75 kW BRE024V Thermoklick	
	080V/4 B14 F120 1.10 kW BRE024V Thermoklick	
	080V/4 B14 F120 1.10 kW BRE230V	
071V/4 B14 P105 0.55 kW BRE024V Thermoklick		
TR2200A	090L/4 B14 P140 1.50 kW BRE024V 20 Nm Thermoklick	
	090L/4 B14 P140 1.50 kW BRE230V 20 Nm Thermoklick	
	090S/4 B14 P140 1.10 kW BRE024V 20 Nm Thermoklick	
	090S/4 B14 P140 1.10 kW BRE230V 20 Nm Thermoklick	
	090L/6 B14 F140 1.10 kW BRE024V 20 Nm Thermoklick	
	090L/6 B14 F140 1.10 kW BRE230V 20 Nm Thermoklick	
	100L/06 B14 F160 1.50 kW BRE024V 20 Nm Thermoklick	
	100L/06 B14 F160 1.50 kW BRE230V 20 Nm Thermoklick	
	090L/8 B14 F140 0.55 kW BRE024V 20 Nm Thermoklick	
	090L/8 B14 F140 0.55 kW BRE230V 20 Nm Thermoklick	
	100L/08 B14 F160 1.10 kW BRE024V 20 Nm Thermoklick	
	100L/08 B14 F160 1.10 kW BRE230V 20 Nm Thermoklick	
	100L/12 B14 F160 0.37 kW BRE024V 20 Nm Thermoklick	

Product type	Type	Manufacturer
	100L/12 B14 F160 0.37 kW BRE230V 20 Nm	
	100S/4 B14 P160 2.20 kW BRE024V 20 Nm Thermoklick	
	090V/8 B14 F140 0.75 kW BRE024V Thermoklick	
	090V/8 B14 F140 0.75 kW BRE230V	

4.3 Holding brake

Refer to the documentation of the manufacturer for the technical data of the holding brake; see applicable documents.

Characteristic	Value
Supply voltage holding brake	See order confirmation

Integrated into motor (motor size)	Voltage	Input power at 20°C	Power coil at 20°C
71 and 80	24 V DC	1.25 A	30 W
71 and 80	205 V DC	0.15 A	30 W
90 and 100	24 V DC	1.25 A	30 W
90 and 100	205 V DC	0.15 A	30 W

4.4 Inductive sensor

Refer to the documentation of the manufacturer for the technical data of the inductive sensor; see applicable documents.

Depending on the order, the following inductive sensor is installed:

Product type	Type	Manufacturer
TR0750A	NBB2-8GM40-E2-V3 3RG4011-7GB33-PF	Pepperl+Fuchs-Gruppe
TR1100A, TR1500A, TR2200A	NBB4-12GM30-E2-V1 NBB4-12GM30-E0-V1	

4.5 DRIVE-CLiQ encoder (optional)

Refer to the documentation of the manufacturer for the technical data of the optional encoder; see applicable documents.

Type	Manufacturer
6FX2001-5FD25-1AA0	SIEMENS AG

4.6 Climatic environmental conditions "Operation"

Characteristic	Unit	Value
Ambient temperature	°C	+10 ... +40
Relative humidity, non-condensing	%	+5 ... +95
Maximum surface temperature	°C	+100
Maximum installation altitude above mean sea level without derating motor and drive/frequency inverter	m	1000

4.7 Climatic environmental conditions "Transportation and Storage"

Characteristic	Unit	Value
Ambient temperature	°C	+5 ... +60
Relative humidity, non-condensing	%	+5 ... +95
Maximum storage duration of the mechanical components	-	see chapter 7.1

4.8 Dimensions

Product type: TR0750A

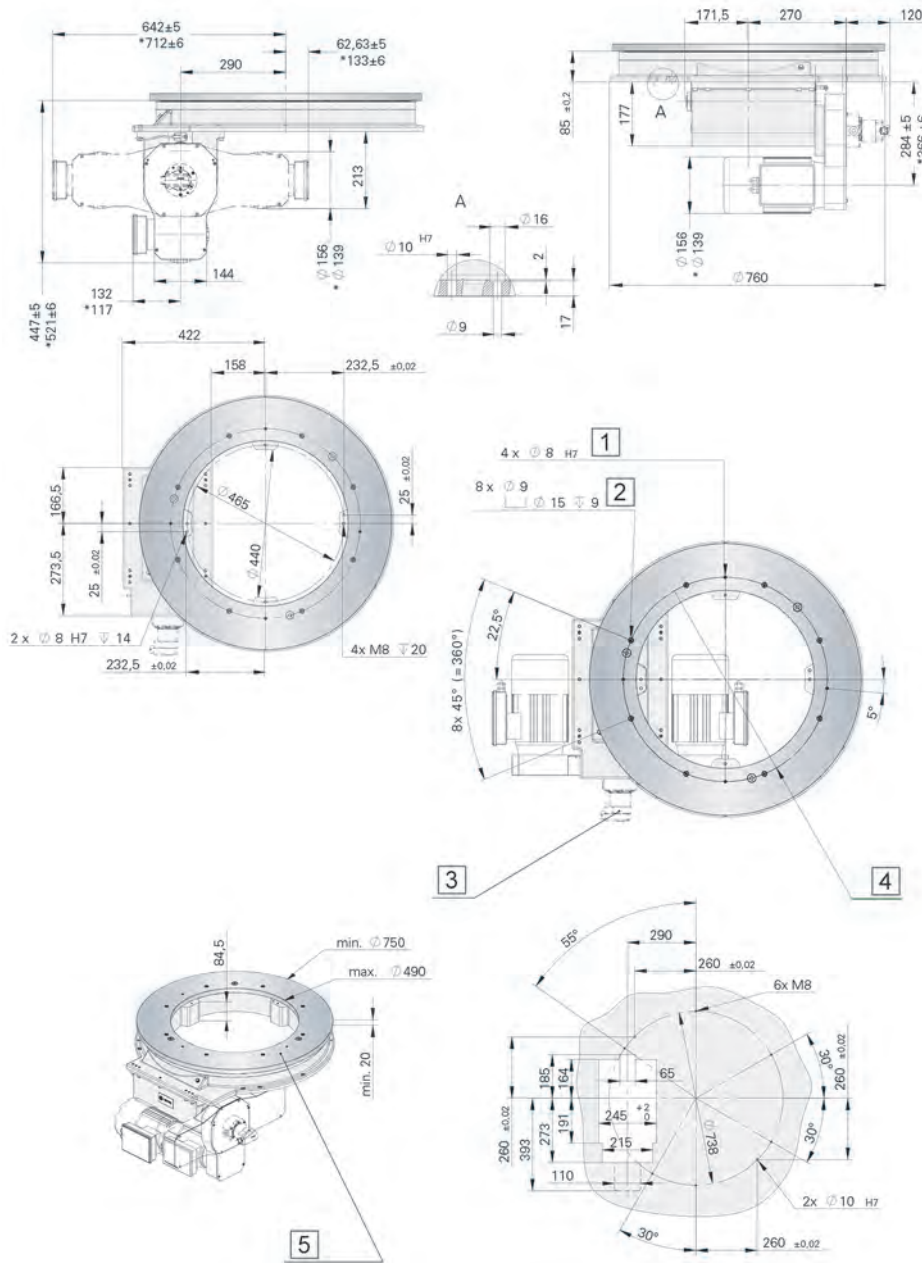

Figure 2: Lengths and diameters in mm
 * Dimensions with motor size 71 (dual-stage)

- | | |
|--|--|
| <p>1 Through hole</p> <p>2 Through hole</p> <p>3 DRIVE-CLiQ encoder (optional)</p> | <p>4 $\text{Ø } 563 \pm 0.1; \pm 0.02$ at $\text{Ø } 8 \text{ H7}$</p> <p>5 Plate is customer-specific. Do not drill through the plate in the minimum area/maximum area.</p> |
|--|--|

Product type: TR1100A

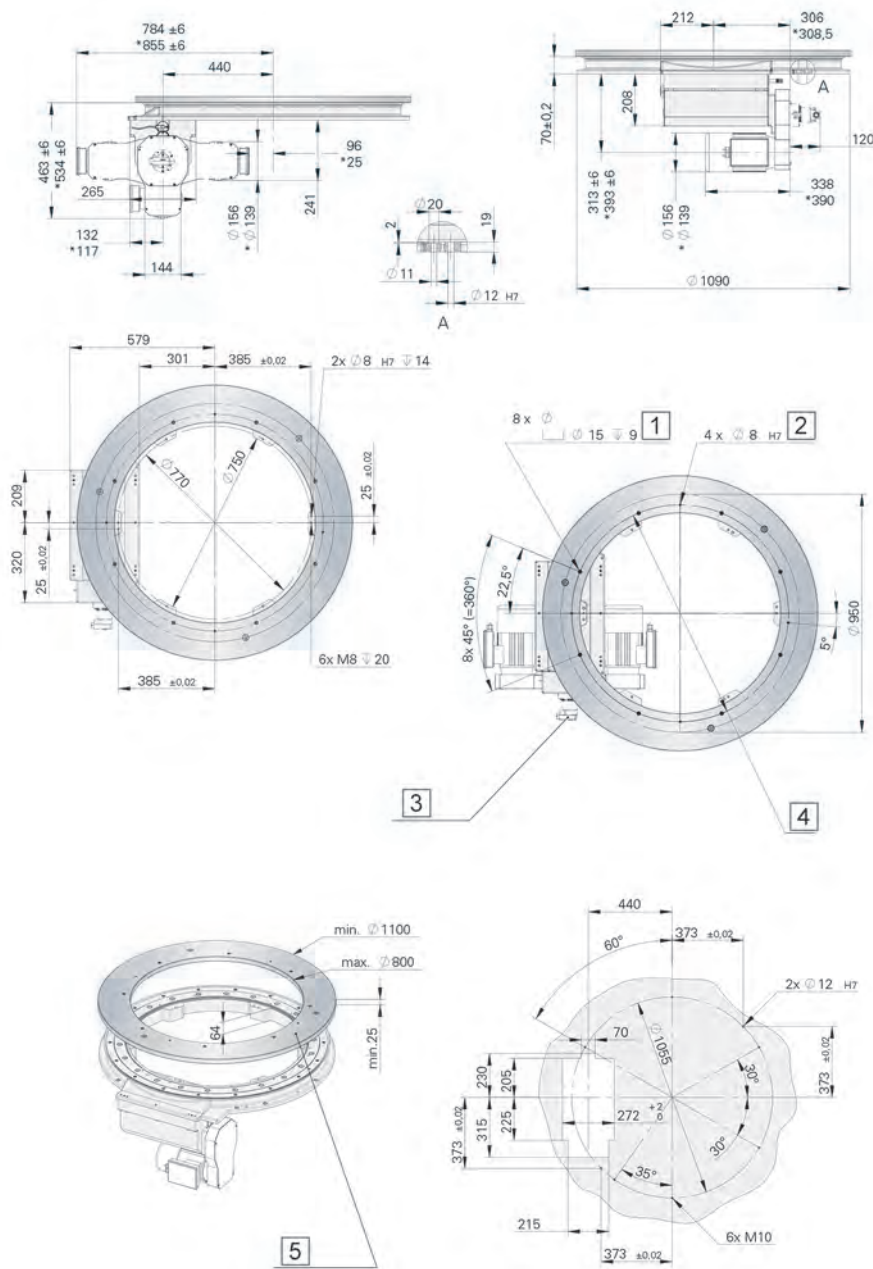

Figure 3: Lengths and diameters in mm
 * Dimensions with motor size 71 (dual-stage)

- | | |
|--|--|
| <p>1 Through hole</p> <p>2 Through hole</p> <p>3 DRIVE-CLiQ encoder (optional)</p> | <p>4 $\varnothing 865.5 \pm 0.1; \pm 0.02$ at $\varnothing 8$ H7</p> <p>5 Plate is customer-specific. Do not drill through the plate in the minimum area/maximum area.</p> |
|--|--|

Product type: TR1500A

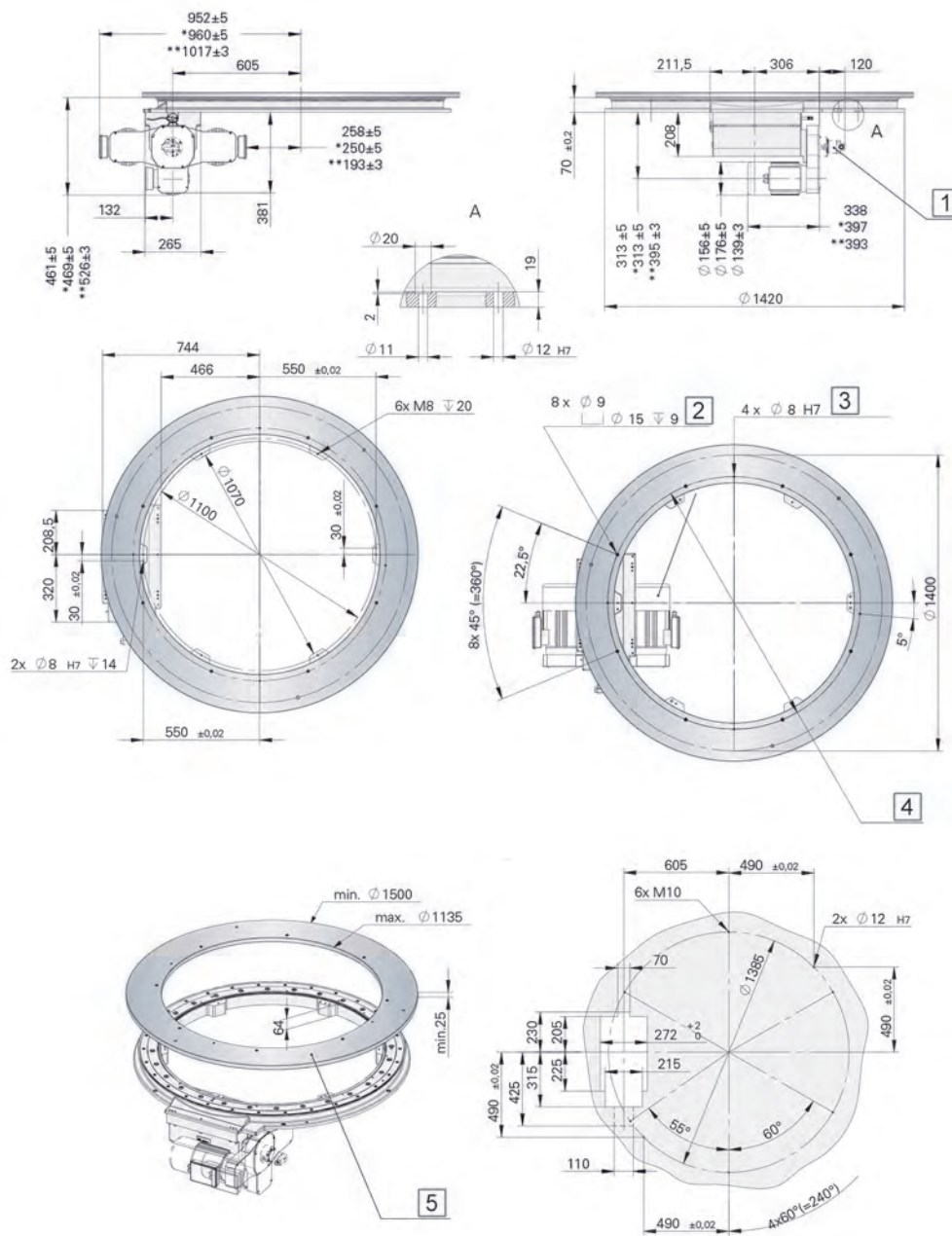

Figure 4: Lengths and diameters in mm

* Dimensions with motor size 90

** Dimensions with motor size 71 (dual-stage)

- | | |
|--|---|
| <p>1 DRIVE-CLiQ encoder (optional)</p> <p>2 Through hole</p> <p>3 Through hole</p> | <p>4 $\varnothing 1195.5 \pm 0.1; \pm 0.02$ at $\varnothing 8 H7$</p> <p>5 Plate is customer-specific. Do not drill through the plate in the minimum area/maximum area.</p> |
|--|---|

Product type: TR2200A

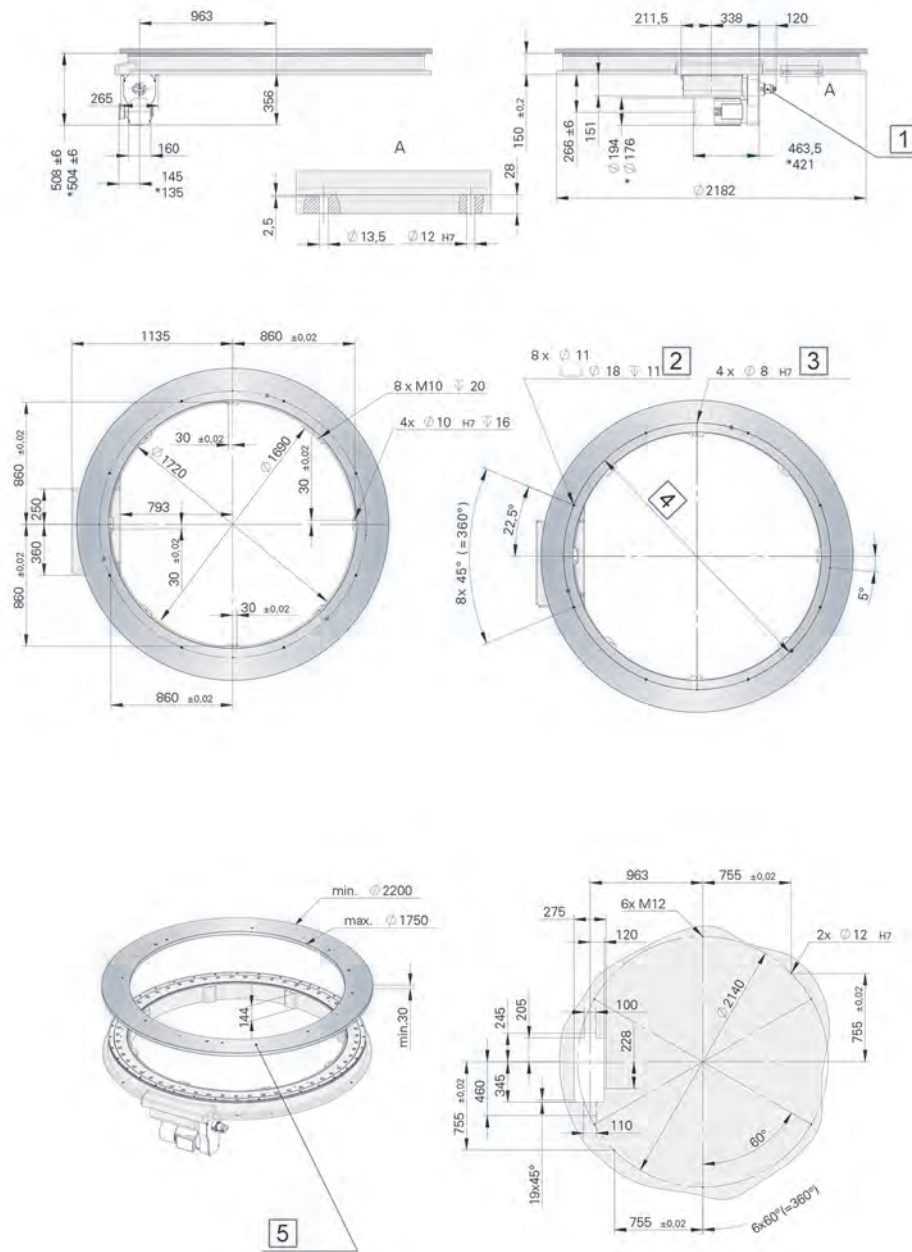

Figure 5: Lengths and diameters in mm
 * Dimensions with motor size 90

- | | |
|--|---|
| <p>1 DRIVE-CLiQ encoder (optional)</p> <p>2 Through hole</p> <p>3 Through hole</p> | <p>4 $\varnothing 1880 \pm 0.1; \pm 0.02$ at $\varnothing 8$ H7</p> <p>5 Plate is customer-specific. Do not drill through the plate in the minimum area/maximum area.</p> |
|--|---|

4.9 Load data

Load data for output flange

Characteristic	Unit	TR0750A	TR1100A	TR1500A	TR2200A
Torque at standstill	Nm	2500	3500	5000	15000
Permissible moment of tilt during movement	Nm	2500	3500	3200	4500
Permissible axial force during movement	N	7000	12000	16000	30000
Permissible radial force during movement	N	7000	12000	16000	30000

5 Packaging

5.1 Types of packaging

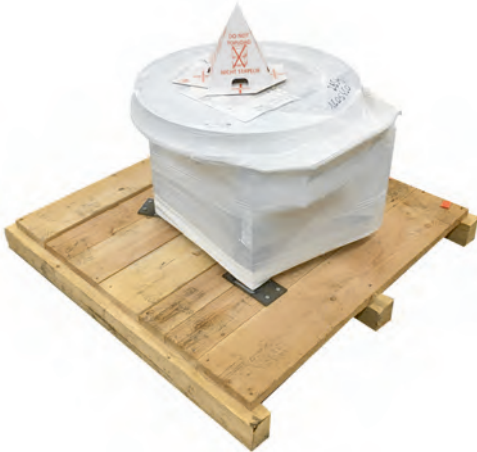

Packaging in Europe

The product is factory-treated with anti-corrosion agent, packaged in film and screwed onto a palette.



Packaging for air and sea freight

The product is factory-treated with anti-corrosion agent, packaged in Corpac-coex-VCI film, screwed onto a palette, and then packed into a wooden box with foam plastic material.

5.2 Unpacking the product

1. Do not remove the packaging until immediately prior to mounting.
2. Dispose of the packaging material in compliance with all directives, standards, and safety regulations applicable at the installation site.

5.3 Verification of the delivery

- Check the delivery for completeness and transportation damage upon reception.
- In the case of damage, reject the delivery or accept it only conditionally.
- Document the damage in the transportation documents/bill of delivery (any damage detected must be immediately reported to the forwarding agent and confirmed by the forwarding agent).
- Take photographs of the damage.
- Report the damage to WEISS GmbH.

6 Transportation



⚠ WARNING

FALLING, TOPPLING, OR LOWERING LOADS

Insufficiently rated load lifting and handling equipment may break. Transportation vehicles, lifting gear, chains, belts, and other equipment not rated for the product may fail or tilt.

Failure to follow these instructions can result in death, serious injury, and equipment damage.

- Only use transportation vehicles, lifting gear, chains, belts, and other lifting and handling equipment that comply with all applicable regulations and that are rated for the weight of the product including packaging.
- Verify that there are no persons in the danger zone.
- Verify that the product is properly secured against falling and toppling.

6.1 Transporting the product

Packages fastened to a pallet can be transported with a fork lift truck, a pallet jack or similar transportation means. Verify that the transportation means used is suitable and approved for the weight and the dimensions of the package.



1. Place the forks below the pallet.
2. Verify that the pallet with the package fully rests on the forks.
3. Fasten the pallet with the package using additional straps if the center of gravity is not in the center of the pallet.

6.2 Load lifting and handling equipment

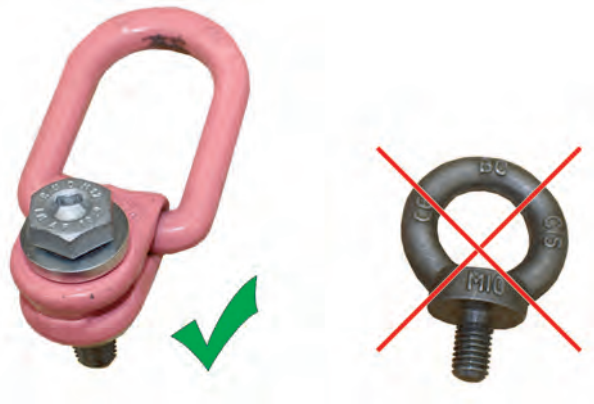

Use properly rated load lifting and handling equipment and hoisting belts/hoisting equipment for transporting the product. Eyebolts must not be used as load lifting and handling equipment.

6.3 Fastening the load lifting and handling equipment



▲ WARNING

FALLING, TOPPLING, OR LOWERING LOADS

Insufficiently rated load lifting and handling equipment may break. Transportation vehicles, lifting gear, chains, belts, and other equipment not rated for the product may fail or tilt.

Failure to follow these instructions can result in death, serious injury, and equipment damage.

- Only use transportation vehicles, lifting gear, chains, belts, and other lifting and handling equipment that comply with all applicable regulations and that are rated for the weight of the product including packaging.
- Verify that there are no persons in the danger zone.
- Verify that the product is properly secured against falling and toppling.

Observe the maximum engagement thread for the load lifting and handling equipment, [see chapter 4.8](#).

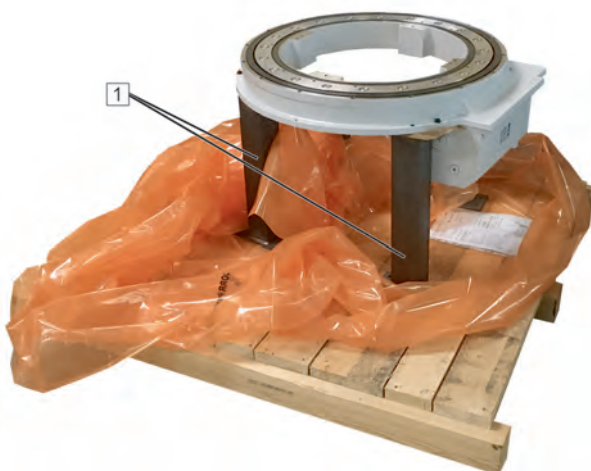

1. Remove the screw connections between the product and the transportation feet [1] before lifting the product.

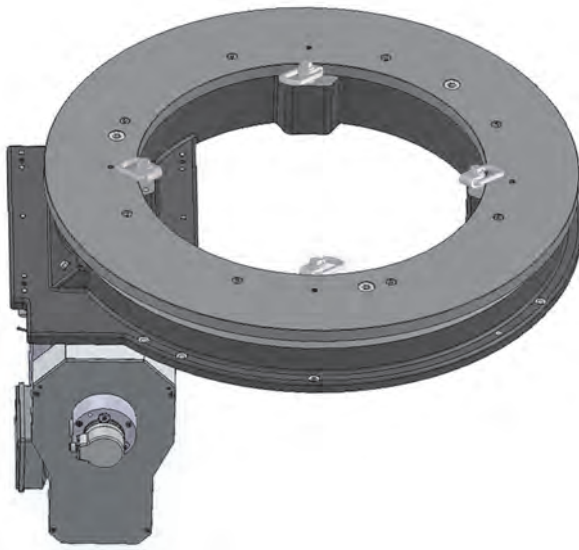

2. Use properly rated load lifting and handling equipment and hoisting belts/hoisting equipment for transporting the product.
3. Screw the load lifting and handling equipment into the threads (see table) at the positions shown in the drawing.
4. Fasten the hoisting belts or the hoisting equipment to the eyelets of the load lifting or load handling equipment.

Product type	Number of pieces of load lifting and handling equipment	Thread
TR0750A, TR1100A, TR1500A	4	M8
TR2200A	4	M12

If the threads for the load lifting and handling equipment mentioned above are covered, it is also possible to lift the product via the output flange/rotary ring.

7 Storage

7.1 Storing the product

NOTICE

INCORRECT STORAGE

Failure to follow these instructions can result in equipment damage.

- Verify compliance with all conditions specified in these mounting instructions and all applicable documents when storing the product.

The mechanical components of the product can be stored for a period of up to two years.

Conditions for specified maximum storage duration:

- Storage in original packaging
- Compliance with all specified storage conditions
- Storage in suitable closed, dry, dust-free room, protected against direct sunlight
- No contact with corrosive media
- Corrosion protection intact

The electrical components have a different maximum storage duration (see documentations of the manufacturers).

If the maximum storage duration has been exceeded, you must contact the manufacturer prior to commissioning the product. This also applies if the machine in which the product has been incorporated has not been operated for a period of time exceeding the maximum storage durations specified for the mechanical and electrical components.

If you plan to store the product for a period of time exceeding the maximum permissible storage duration specified for the mechanical components, you must uninstall the electrical components prior to storing the product. The electrical components must be stored according to the specifications of the manufacturers (see documentations of the manufacturers).

If the product is to be stored for a period of more than three months, the product must first be preserved. If the factory-applied anti-corrosion agent is no longer intact, you must request preservation instructions from the manufacturer.

8 Mounting

8.1 Prerequisites for mounting

Prior to mounting, the anti-corrosion and any pollution must be removed with a standard solvent.

NOTICE

DAMAGE TO SHAFT SEALING RINGS

Failure to follow these instructions can result in equipment damage.

- Avoid any contact of the sealing lips of the shaft sealing rings with the solvent.

Prior to mounting, verify that the dimensions of the installation site and construction conditions meet the requirements and the dimensions specified in these mounting instructions and the applicable documents.

- Verify that the supporting base is level and rigid.

Product type	Maximum permissible flatness error	Maximum permissible surface roughness
TR0750A	0.090 mm	Rz 6.3 ... Rz 16
TR1100A	0.105 mm	
TR1500A	0.125 mm	
TR2200A	0.175 mm	

- Verify that the supporting structure at the installation site has a sufficient structural strength to carry the weight of the product and of all loads.
- Verify that the motor is easily accessible for service and maintenance work.
- Verify that there is a minimum distance of 100 mm between the motor fan and other assemblies.
- Verify that free convection for removing the hot air is not obstructed.

8.2 Equipment and tools

The following is required for mounting:

- Set of wrenches
- Set of hex keys
- Set of screwdrivers
- Torque wrench
- Plastic hammer
- Ball pane hammer
- Cotter pin punch (for mounting the parallel pins)
- Standard solvent
- Mounting grease
- Brush (for mounting grease)

8.3 Tightening torques and property classes

For fastening the product, only use screws with the property class shown in the following table unless a different property class is explicitly specified for a screw connection.

Use the tightening torque shown in the following table unless a different tightening torque is explicitly specified for a screw connection.

Property class of screws	10.9 (coefficient of friction $\mu_{\text{tot.}}$ 0.12)		
Product type	TR0750A	TR1100A, TR1500A	TR2200A
Thread	M8	M10	M12
Tightening torque	34 Nm	68 Nm	117 Nm
Nominal dimensions for pin holes	10 mm	12 mm	12 mm

8.4 Bolting down the product



⚠ WARNING

FALLING, TOPPLING, OR LOWERING LOADS

Insufficiently rated load lifting and handling equipment may break. Transportation vehicles, lifting gear, chains, belts, and other equipment not rated for the product may fail or tilt.

Failure to follow these instructions can result in death, serious injury, and equipment damage.

- Only use transportation vehicles, lifting gear, chains, belts, and other lifting and handling equipment that comply with all applicable regulations and that are rated for the weight of the product including packaging.
- Verify that there are no persons in the danger zone.
- Verify that the product is properly secured against falling and toppling.



⚠ WARNING

IMPROPERLY FASTENED PARTS

Failure to follow these instructions can result in death, serious injury, and equipment damage.

- Verify that the supporting structure and/or the frame and/or the mounting surface for fastening the product are sufficiently rated to withstand all static and dynamic loads and forces during operation.
- Verify that the fastening parts comply with the specifications indicated and that they are sufficiently rated for all load conditions during operation.

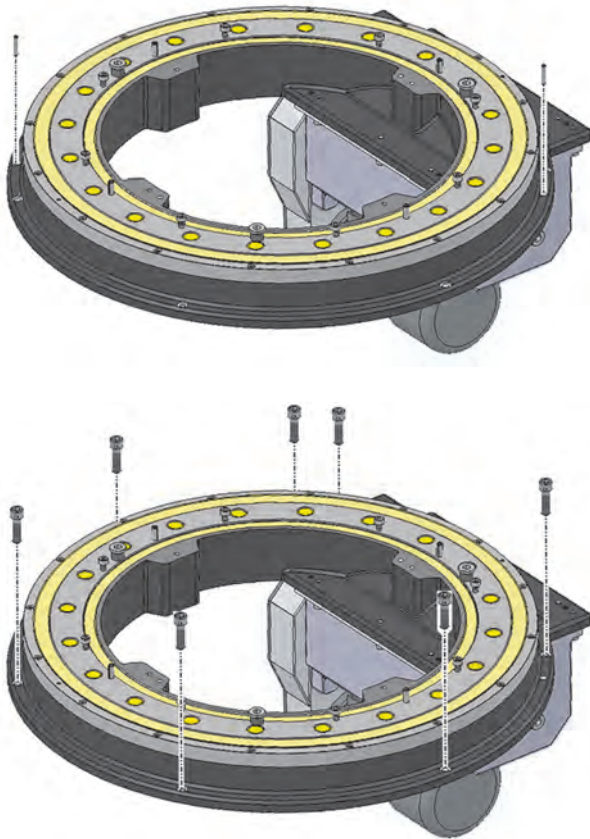

Use screws with the property class specified to mount the product, [see chapter 8.3](#). When determining the length of the screws, take into account the loads and forces acting in your application as well as the characteristics of the supporting structure to which the product is mounted.

1. Place the product at the mounting site in compliance with the transportation instructions and align it according to the holes and the pin holes.
2. Center the product with two parallel pins and then drive in the first parallel pin by one third.
3. Screw in all screws and tighten them.
4. Drive in all parallel pins (positive fit, the parallel pin must be in contact with the housing of the indexing table and the supporting surface/mounting surface).
5. Tighten all screws cross-wise with the specified tightening torque.

8.5 Displacing the drive housing



⚠ WARNING

FALLING PARTS

Failure to follow these instructions can result in death, serious injury, and equipment damage.

- Secure the motor so it cannot fall down before loosening the screws.

The drive housing is factory-mounted according to the drive position you specify in your order. The drive housing can be moved to the permissible drive positions, [see chapter 3.6](#).

Mounting

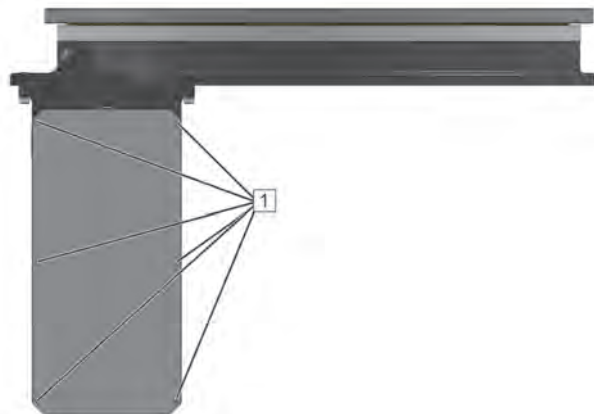

The output flange must be in a locked position before the drive housing is displaced. When the product is delivered, the output flange is in one of the possible locked positions.

1. Remove the cover [1] by removing the screws.

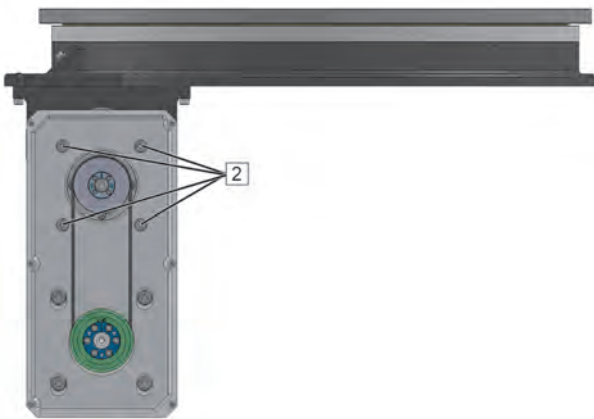

2. Remove the four screws [2].

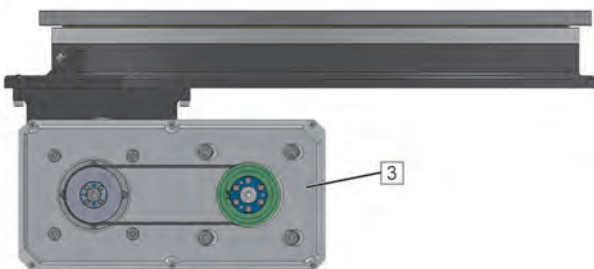

3. Turn the drive housing [3] to the required position (the illustration shows the drive housing turned by 90° to the inside).

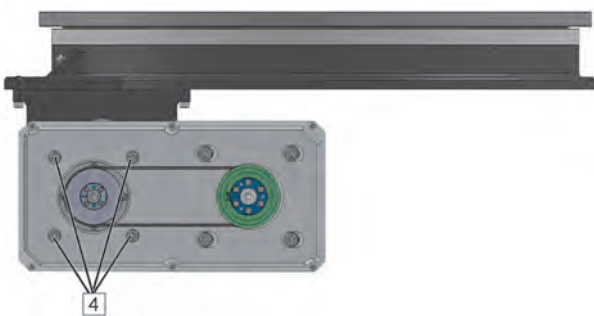

4. Fit the four screws [4] of the drive housing and tighten them cross-wise.
 - ✓ The toothed belt is correctly tensioned if it can be manually twisted by - depending on the length of the toothed belt - 45° to 90° along the longitudinal axis in the center between the two pulleys.
 - ✓ Contact WEISS GmbH if you need the frequency for adjusting the toothed belt with a belt tension meter.

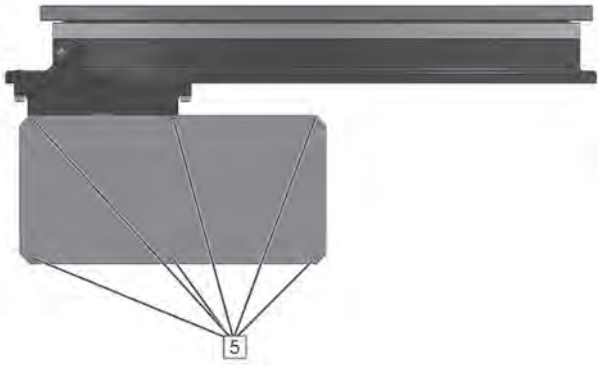

5. Mount the cover by means of the screws [5].
6. Remove all tools and equipment.
7. Perform a test run.

8.6 Mounting additional components



⚠ WARNING

IMPROPERLY FASTENED PARTS

Failure to follow these instructions can result in death, serious injury, and equipment damage.

- Verify that the supporting structure and/or the frame and/or the mounting surface for fastening the product are sufficiently rated to withstand all static and dynamic loads and forces during operation.
- Verify that the fastening parts comply with the specifications indicated and that they are sufficiently rated for all load conditions during operation.



⚠ CAUTION

INCORRECT MOUNTING OF ADDITIONAL COMPONENTS

Failure to follow these instructions can result in injury or equipment damage.

- Only mount components to the rotary ring/stationary plate that are approved by the manufacturer.
- Only use existing holes for mounting additional components to the rotary ring/stationary plate.
- After mounting, do not drill holes into the rotary ring/stationary plate.
- Do not perform welding work at the rotary ring/stationary plate.

NOTICE

BLOCKING OF THE PRODUCT DUE TO EXTRANEIOUS OBJECTS

Mounting an additional indexing plate or an attachment plate creates a gap through which extraneous objects can get into the product.

Failure to follow these instructions can result in equipment damage.

- Mount a suitable lip seal between the rotating plate and the stationary plate.
- Verify that the lip seal does not collide with the existing holes.

Mounting a rotary ring

A rotary ring may only be mounted via the fit holes and threads provided.

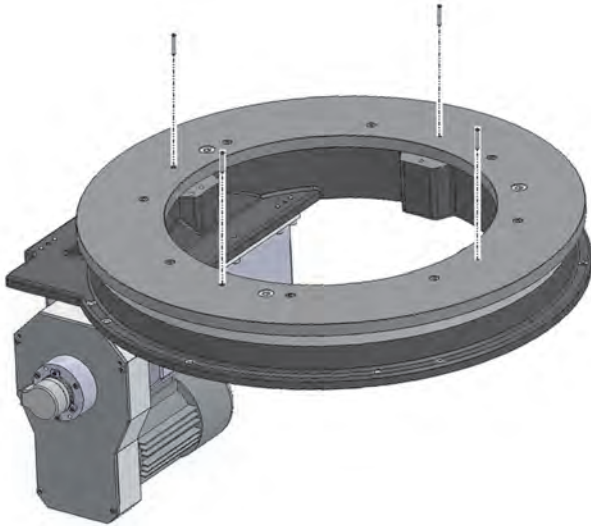

1. Place the rotary ring onto the output flange.
2. Center the four parallel pins and then drive in the first parallel pin by one third of the way.
3. Screw in all screws and tighten all screws.
4. Fully drive in all parallel pins.
5. Tighten all screws cross-wise with the specified tightening torque, [see chapter 8.2](#).

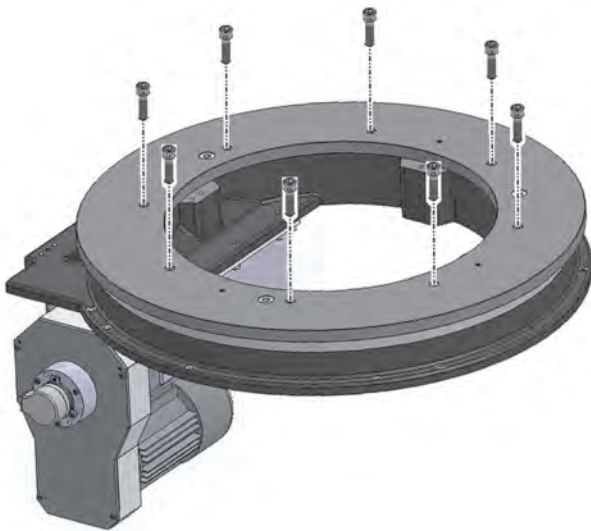

Mounting a raised ring

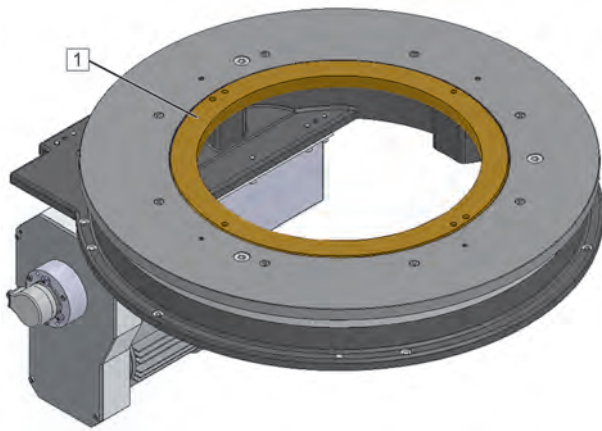

1. Place the raised ring [1] on the mounting surface.
2. Center the two parallel pins and then drive in the first parallel pin by one third of the way.

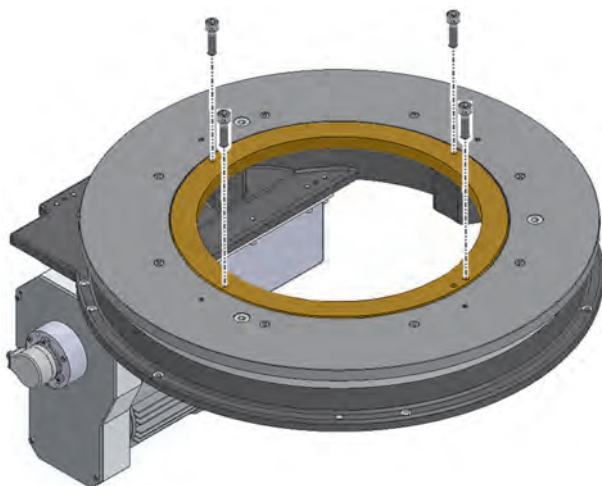
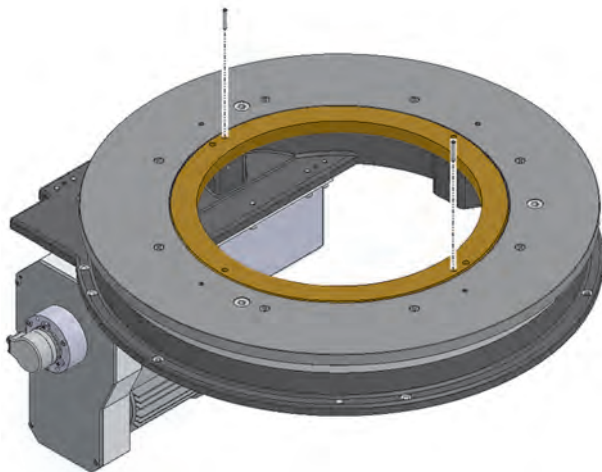

3. Screw in all screws and tighten all screws.
4. Fully drive in all parallel pins.
5. Tighten all screws cross-wise with the specified tightening torque, [see chapter 8.2](#).

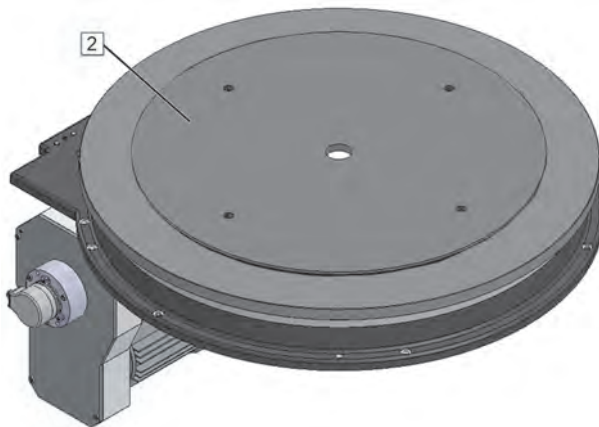

6. Now you can mount a stationary plate [2] onto the raised ring.

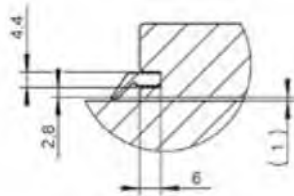

7. Mount a suitable lip seal between the rotary ring and the stationary plate to help avoid the ingress of extraneous objects.

Lip seal outside

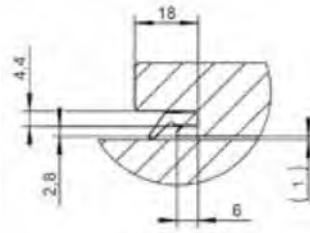

Lip seal inside

8.7 Mounting safety equipment

The product is a partly complete machine pursuant to Directive 2006/42/EU and intended to be incorporated into or assembled with other machinery. The requirements concerning functional safety and the corresponding safety equipment result from the risk analysis and the risk assessment for the final machine or plant.

Selection, mounting, installation, commissioning, operation and maintenance of the safety equipment must be performed by the system integrator (the person who incorporates the product in a machine pursuant to Directive 2006/42/EU, i.e., for example, the machine builder) and/or the operator.

The product requires at least the following safety equipment:

- Emergency Stop system as per IEC 60204-1 / ISO 13850
- Lockable main switch to interrupt the complete power supply to all electrical components of the product

9 Electrical connection



⚠ DANGER

ELECTRIC SHOCK CAUSED BY LIVE PARTS

Failure to follow these instructions will result in death or serious injury.

- Disconnect the mains supply voltage before performing the work and ensure that it cannot be switched on.
- Verify that no hazards can be caused by electrically conductive objects.
- Verify that all cables for the power supply are disconnected from power.



⚠ DANGER

ELECTRIC SHOCK DUE TO MISSING COVERS

Failure to follow these instructions will result in death or serious injury.

- Verify that all removed covers are re-installed, and all terminal boxes are closed after you have performed work.



⚠ WARNING

UNANTICIPATED MOVEMENT

Interchanging the motor connections inverts the direction of rotation of the motor.

Failure to follow these instructions can result in death, serious injury, and equipment damage.

- Verify correct wiring and connection of all electrical connections.



⚠ CAUTION

IMPROPERLY INSTALLED CABLES

Failure to follow these instructions can result in injury or equipment damage.

- Verify that the cables are correctly routed.
- Verify compliance with the bend radius specifications for the electrical lines.
- Only use cables with the correct cross sections.
- Verify that the electrical cables are correctly connected to the terminals.

The following components must be connected for the motor:

- Lockable main switch
- Suitable Emergency Stop equipment (as per IEC 60204-1 / EN ISO 13850)

9.1 Connection diagram supply voltage

The terminal box of the motor contains a wiring diagram for the connection of the power supply for the motor and for the holding brake.

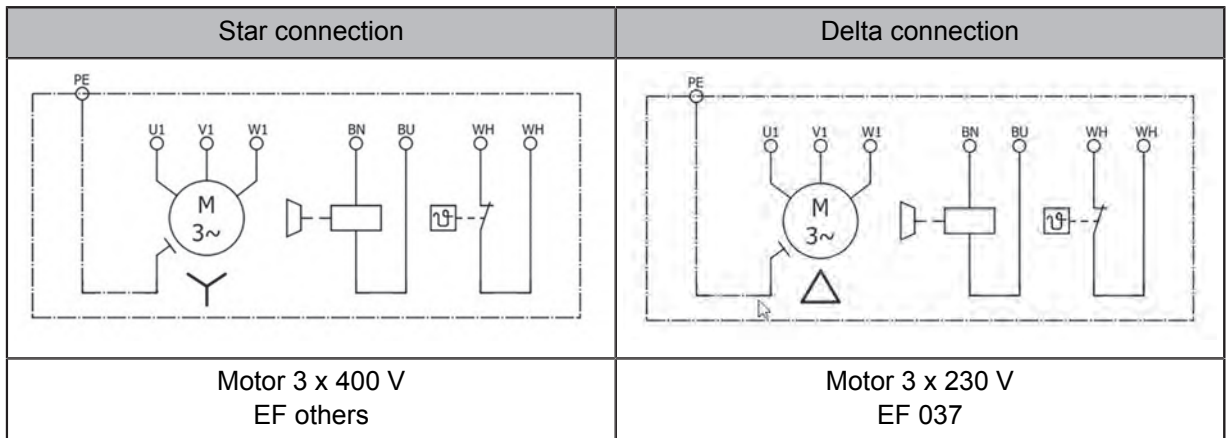

10 Controller

10.1 Basic information on control



▲ WARNING

LOSS OF CONTROL

Failure to follow these instructions can result in death, serious injury, and equipment damage.

- Consider all potential failure modes of all control paths in your control concept.
- Implement means and measures for all critical functions to achieve a safe state if a control path fails (for example, emergency stop, overtravel of positions, power outage, and restart).
- Implement separate or redundant control paths for all critical functions.
- If the control system of the machine comprises communication links, consider the consequences of unanticipated transmission delays or failures of the link and implement appropriate measures.
- Subject each machine in which the product described in these mounting instructions is used to a comprehensive and thorough commissioning test before operating the machine.

The output flange can be operated with the following directions of movement: left, right, or alternating.

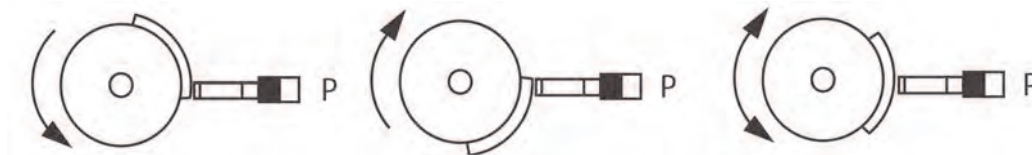

A movement of the output flange is started by sending a start signal to the motor and applying the holding brake voltage. This releases the holding brake and the motor accelerates.

To stop the movement of the output flange, a stop signal is sent to the motor and the motor decelerates to a standstill. After the motor has decelerated to a standstill, the supply voltage to the holding brake is removed. This applies the holding brake. The output flange is at one of the possible positions.

The holding brake is not a service brake, i.e. it is not used to decelerate the load to a standstill, but to maintain the load at a standstill.

If no external controller is used, the gear determines the cycles.

The cycle time is fixed (determined via the gear) or it can be adjusted via the controller.

A signal "P" (output flange in position) can be generated via the inductive sensor. This signal can be used to control the motor and the holding brake; the signal can also be used as a start signal for processing units.

10.2 External controller (PLC)



WARNING

UNINTENDED MOVEMENT OR LOSS OF CONTROL

If the signal "P" becomes inactive without the PLC having started a new cycle, this output flange is not in the correct position. Usually, this means that the stop position has been overtraveled. This can result in damage to the product, to the processing stations, and to the parts being machined, as well as in other hazards.

Failure to follow these instructions can result in death, serious injury, and equipment damage.

- Verify that the state of the signal "P" from the inductive sensor is always available to the PLC.
- Immediately stop the machine if the signal "P" becomes inactive without the PLC having started a new cycle.

An external controller is a controller provided by the customer.

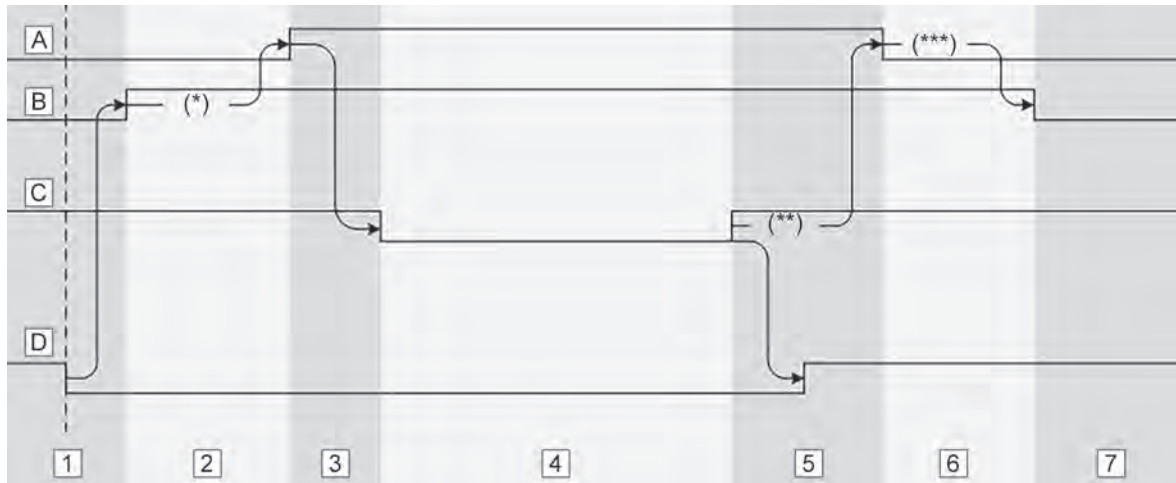

- | | |
|--|--|
| <p>A Motor</p> <p>B Holding brake</p> <p>C Signal "P" from inductive sensor</p> <p>D Process</p> | <p>3 The motor starts at the beginning of phase 3. This moves the position cam out of the measurement field of the inductive sensor. At the end of phase 3, signal "P" from the inductive sensor is no longer active.</p> <p>4 Output flange rotates</p> <p>5 Output flange is at a standstill, time delay (**) for deceleration of the motor is running. The time delay depends, among other things, on the speed and the indexing stops.</p> <p>6 Time delay (***) for application of the holding brake is running. The time delay depends, among other things, on the speed and the indexing stops.</p> <p>7 Product ready for the next cycle. Signal "P" from the inductive sensor is active (position cam in measurement field).</p> |
|--|--|

2 Time for releasing the holding brake (*).

WEISS motor

Type: 71L = 30 ms

WEISS motor

Type: 71V / 80L / 80V / 90L / 90V / 100L = 90 ms

Third-party motor

This time results from the physical design of the holding brake (refer to the documentation of the manufacturer).

Overtravel of the stop position can be caused by contact erosion of the contacts of the motor contactor.

1. Check the motor contactor (see documentation of the manufacturer).

11 Commissioning

11.1 Prerequisites for commissioning

The following requirements must be met before the product may be commissioned:

- The product is properly mounted.
- The electrical equipment for the power supply of the motor and the holding brake is mounted correctly.
- All cables are properly routed and connected.
- All electrical connections have been made properly.
- All parts of the system are properly grounded in compliance with all applicable directives, regulations, and standards.
- All safety equipment and EMERGENCY-STOP circuits are operational.
- The drive is not damaged and not blocked.
- All environmental conditions are respected.
- All protective covers are properly mounted.
- The toothed belt has the correct tension.
- All tools, equipment, and other objects have been removed from the zone of operation of the product.
- All hazards are excluded.

Prior to commissioning, perform a test for each prerequisite mentioned and verify compliance with all information and specifications contained in these mounting instructions, in all applicable documents, and in all applicable directives, regulations, and standards.

11.2 Performing commissioning



WARNING

UNANTICIPATED MOVEMENT

Incorrect connections or external influences on electrical equipment can cause unanticipated movements.

Failure to follow these instructions can result in death, serious injury, and equipment damage.

- Verify correct wiring.
- Verify that there are no persons or obstacles in the danger zone of the product before starting the product.
- Perform initial test movements without loads and without other processing units.
- Verify that all safety equipment and EMERGENCY STOP circuits are activated prior to commissioning.



⚠ WARNING

UNINTENDED EQUIPMENT OPERATION

Incorrect or unsuitable parameter values or settings can cause unintended movements, trigger signals, and compromise functional safety.

Failure to follow these instructions can result in death, serious injury, and equipment damage.

- Verify that parameter values and settings can only be modified by authorized personnel who fully understand each and every effect of such a modification.
- Verify that all parameter values and settings are correct by performing a test run.



⚠ WARNING

ELECTROMAGNETIC RADIATION

Failure to follow these instructions can result in death, serious injury, and equipment damage.



- Verify compliance with all international, national, and local directives, standards, and safety regulations, including all regulations concerning workplace safety and prevention of accidents, with regard to electromagnetic radiation.
- Take all necessary measures to ensure that persons with active medical implants (such as heart pacemakers or insulin pumps), metal implants, and magnetically or electrically conductive objects are not exposed to the electromagnetic fields generated by the motor.

Power on the power supply to the product via the main switch.

Check the following points during commissioning:

- Operating state, potential error conditions, and protective equipment
 - During commissioning, perform tests for all operating states and error conditions. In doing so, verify that all protective equipment operates as planned and required.
- Correct operation of the motor
 - There are no overloads.
 - There are no unusual fluctuations in the speed of rotation. Immediately stop the product in the case of overloads or unusual fluctuations in the speed of rotation and verify correct mounting.
- Noise emission
 - Excessive noise emission can be an indication of incorrect mounting, for example, an uneven ground that causes mechanical stress at the rotary ring. Immediately stop the product in the case of high noise emission and verify correct mounting.
- Heat
 - Verify that the heat dissipation is sufficient and that the specified climatic environmental conditions are respected by performing a test run under maximum load conditions.

If the product and/or the machine into which the product is incorporated is temporarily decommissioned, it must be recommissioned. For recommissioning, the same prerequisites must be met as for initial commissioning.

Perform the same tests for each recommissioning of the product as for initial commissioning.

12 Operation

12.1 Basic information on operation



⚠ WARNING

UNINTENDED EQUIPMENT OPERATION

Incorrect or unsuitable parameter values or settings can cause unintended movements, trigger signals, and compromise functional safety.

Failure to follow these instructions can result in death, serious injury, and equipment damage.

- Verify that parameter values and settings can only be modified by authorized personnel who fully understand each and every effect of such a modification.
- Verify that all parameter values and settings are correct by performing a test run.



⚠ WARNING

ELECTROMAGNETIC RADIATION

Failure to follow these instructions can result in death, serious injury, and equipment damage.



- Verify compliance with all international, national, and local directives, standards, and safety regulations, including all regulations concerning workplace safety and prevention of accidents, with regard to electromagnetic radiation.
- Take all necessary measures to ensure that persons with active medical implants (such as heart pacemakers or insulin pumps), metal implants, and magnetically or electrically conductive objects are not exposed to the electromagnetic fields generated by the motor.

The product is a partly complete machine pursuant to Directive 2006/42/EU and intended to be incorporated into or assembled with other machinery. The information required for operation results from the functionality of the machine or system into which the product is incorporated and from the application implemented with it.

The instructions for the safe operation of the final machine or system must be provided by the system integrator (the person who incorporates the product in a machine pursuant to Directive 2006/42/EU) and/or the operator in the form of a manual with operating instructions, [see chapter 2.3](#).

These operating instructions must be a complete manual which describes all work on and with the product and which contains all information relevant to the product. The system integrator and/or operator must ensure compliance of the operating instructions with all applicable directives, regulations, and standards.

13 Troubleshooting

13.1 Issue, cause and remedy



⚠ DANGER

ELECTRIC SHOCK CAUSED BY LIVE PARTS

Failure to follow these instructions will result in death or serious injury.

- Disconnect the mains supply voltage before performing the work and ensure that it cannot be switched on.
- Verify that no hazards can be caused by electrically conductive objects.
- Verify that all cables for the power supply are disconnected from power.



⚠ WARNING

MOVING PARTS

Failure to follow these instructions can result in death, serious injury, and equipment damage.

- Verify that the zone of operation of the moving parts of the product/machine is safeguarded.



⚠ WARNING

HOT SURFACES

The temperature of the motor and the holding brake can exceed 100 °C during operation.

Failure to follow these instructions can result in death, serious injury, and equipment damage.

- Avoid unprotected contact with hot surfaces.
- Do not allow flammable or heat-sensitive objects in the vicinity of hot surfaces.
- Before performing work on the motor or the holding brake, verify that you wait for a sufficient period of time to allow such parts to cool down to a temperature that allows for safe contact.

Issue	Cause	Remedy
Output flange/rotary ring do not rotate	Toothed belt between motor and gear is torn	▪ Replace the toothed belt, see chapter 15.5
	No motor supply voltage	<ul style="list-style-type: none"> ▪ Measure the voltage ▪ Check all fuses ▪ Check the motor protection switch
	Motor is inoperable	▪ Replace the motor, see chapter 15.3



Issue	Cause	Remedy
	Output flange/rotary ring are mechanically blocked	<ul style="list-style-type: none"> ▪ Verify that the output flange/ rotary ring is not mechanically blocked at the top or the underside ▪ Remove the cause of the block
	Pollution between rotary ring and stationary plate	<ul style="list-style-type: none"> ▪ Check the gap between the rotary ring and stationary plate for extraneous objects ▪ Remove extraneous objects
	During initial commissioning: The output flange/rotary ring is subject to mechanical tension	<ul style="list-style-type: none"> ▪ Dismount the stationary plate and the rotary ring and clean the plate and the ring ▪ Perform a test run without rotary ring and stationary plate
Output flange overtravels a position	<ul style="list-style-type: none"> ▪ The rotary switch (controller board) is set to an excessively high stop delay time ▪ Holding brake is worn ▪ If the position is overtraveled from time to time (but at an increasing frequency), this may be caused by contact erosion or wear of the holding brake. ▪ Contact erosion at motor contactor 	<ul style="list-style-type: none"> ▪ Set a correct stop delay time with the rotary switch Modifications to the time setting remedy this condition only for a short period of time ▪ Replace the holding brake, see chapter 15.8 ▪ Replace the motor contactor (use a semiconductor relay, if required)

14 Cleaning

14.1 Performing cleaning



⚠ DANGER

ELECTRIC SHOCK CAUSED BY LIVE PARTS

Failure to follow these instructions will result in death or serious injury.

- Disconnect the mains supply voltage before performing the work and ensure that it cannot be switched on.
- Verify that no hazards can be caused by electrically conductive objects.
- Verify that all cables for the power supply are disconnected from power.



⚠ WARNING

UNANTICIPATED MOVEMENT OF THE ROTARY RING/THE ROTARY RING

The gear is not self-locking. When the drive and the output flange/rotary ring are decoupled, the output flange/rotary ring can move.

Failure to follow these instructions can result in death, serious injury, and equipment damage.

- Block or safeguard the output flange/rotary ring in such a way that a movement of the output flange/rotary ring is safely prevented before releasing the holding brake or decoupling the drive and the output flange/rotary ring.



⚠ WARNING

MISSING PROTECTIVE EQUIPMENT

Failure to follow these instructions can result in death, serious injury, and equipment damage.

- Immediately reinstall protective equipment that you may have removed to perform maintenance work after having completed the maintenance work and verify the effectiveness of the protective equipment.



⚠ WARNING

MOVING PARTS

Failure to follow these instructions can result in death, serious injury, and equipment damage.

- Verify that the zone of operation of the moving parts of the product/machine is safeguarded.



▲ WARNING

HOT SURFACES

The temperature of the motor and the holding brake can exceed 100 °C during operation.

Failure to follow these instructions can result in death, serious injury, and equipment damage.

- Avoid unprotected contact with hot surfaces.
- Do not allow flammable or heat-sensitive objects in the vicinity of hot surfaces.
- Before performing work on the motor or the holding brake, verify that you wait for a sufficient period of time to allow such parts to cool down to a temperature that allows for safe contact.

For cleaning of electrical components and additional components, respect the instructions in the documentations of the manufacturer; see applicable documents.

Use the following cleaning agents for cleaning the product:

Component	Cleaning agents
Housing	Neutral, mildly alkaline
Rotary ring	
Raised ring	
Stationary plate	
Motor	Dry cleaning

1. Remove fine impurities and dust with a dry, lint-free cloth.
2. Use a wet cloth and a neutral, mildly alkaline cleaning agent to remove stains on the housing, the rotary ring, the raised ring, the stationary plate and/or on the output flange.
3. Dry the cleaned areas.
4. Remove all equipment from the product.
5. Restore the readiness for operation of the product.

15 Maintenance

15.1 Maintenance plan

When	Activity
At least once per year	<ul style="list-style-type: none"> ▪ Clean all surfaces of the product, see chapter 14.1
	<ul style="list-style-type: none"> ▪ Verify all screw connections of the product for correct tightening torque
	<ul style="list-style-type: none"> ▪ Verify correct connection of all plug connections
At least every 2 million cycles or once per year	<ul style="list-style-type: none"> ▪ Inspect the toothed belt, see chapter 15.4
If required	<ul style="list-style-type: none"> ▪ Replace the toothed belt, see chapter 15.5
	<ul style="list-style-type: none"> ▪ Replace the motor, see chapter 15.3

15.2 Lubricant

The product features lifetime lubrication.

Refer to the documentation of the manufacturer for information on the lubricants used; see applicable documents.

15.3 Replacing the motor



⚠ DANGER

ELECTRIC SHOCK CAUSED BY LIVE PARTS

Failure to follow these instructions will result in death or serious injury.

- Disconnect the mains supply voltage before performing the work and ensure that it cannot be switched on.
- Verify that no hazards can be caused by electrically conductive objects.
- Verify that all cables for the power supply are disconnected from power.



⚠ WARNING

UNANTICIPATED MOVEMENT OF THE ROTARY RING/THE ROTARY RING

The gear is not self-locking. When the drive and the output flange/rotary ring are decoupled, the output flange/rotary ring can move.

Failure to follow these instructions can result in death, serious injury, and equipment damage.

- Block or safeguard the output flange/rotary ring in such a way that a movement of the output flange/rotary ring is safely prevented before releasing the holding brake or decoupling the drive and the output flange/rotary ring.

**⚠ WARNING****MISSING PROTECTIVE EQUIPMENT**

Failure to follow these instructions can result in death, serious injury, and equipment damage.

- Immediately reinstall protective equipment that you may have removed to perform maintenance work after having completed the maintenance work and verify the effectiveness of the protective equipment.

**⚠ WARNING****MOVING PARTS**

Failure to follow these instructions can result in death, serious injury, and equipment damage.

- Verify that the zone of operation of the moving parts of the product/machine is safeguarded.

**⚠ WARNING****HOT SURFACES**

The temperature of the motor and the holding brake can exceed 100 °C during operation.

Failure to follow these instructions can result in death, serious injury, and equipment damage.

- Avoid unprotected contact with hot surfaces.
- Do not allow flammable or heat-sensitive objects in the vicinity of hot surfaces.
- Before performing work on the motor or the holding brake, verify that you wait for a sufficient period of time to allow such parts to cool down to a temperature that allows for safe contact.

**⚠ WARNING****FALLING PARTS**

Failure to follow these instructions can result in death, serious injury, and equipment damage.

- Secure the motor so it cannot fall down before loosening the screws.

Dismounting the motor

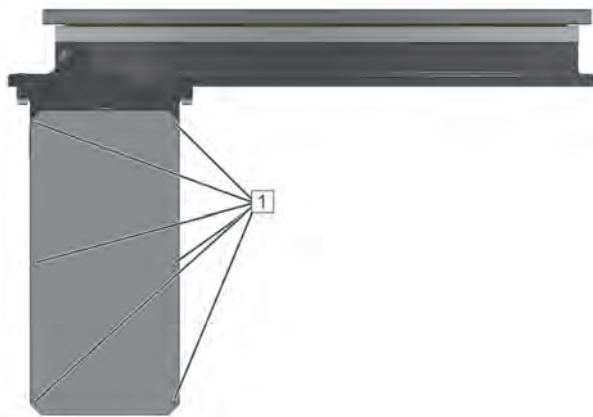

The product must be in a locked position before the motor is replaced.

1. Disconnect the motor and the holding brake (see operating instructions of the motor manufacturer).
2. Remove the cover [1] by removing the screws.

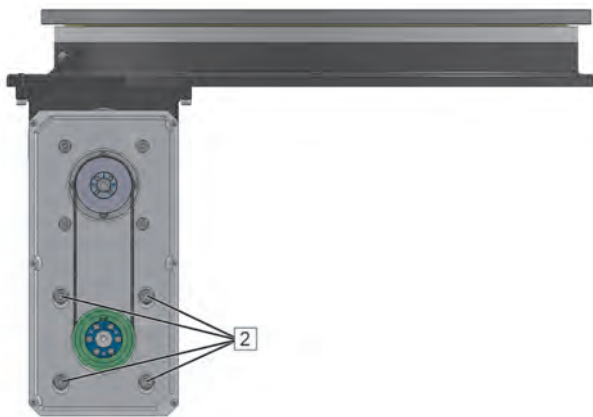

3. Loosen the four screws [2] of the motor flange.

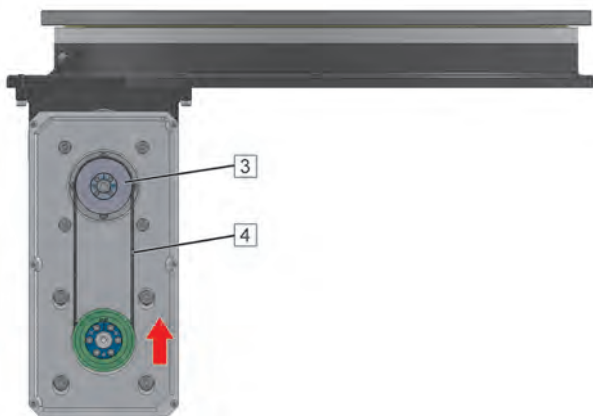

4. Slacken the toothed belt [4] by moving the motor in the motor in the elongated holes.
5. To remove the toothed belt [4], start by pulling the toothed belt off of the toothed belt pulley (gear) [3].

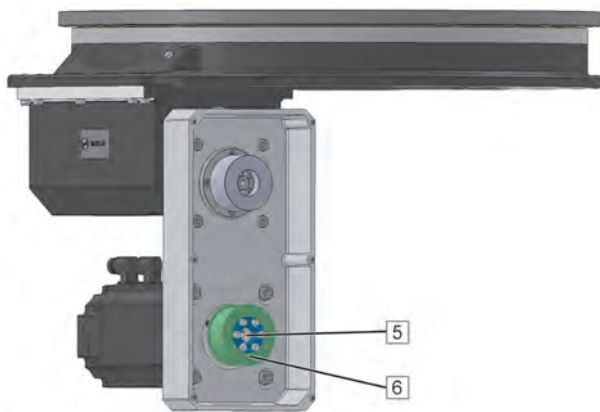

6. Remove the screws [5] of the pulley.
7. Pull the toothed belt pulley (motor) [6] off of the motor shaft.

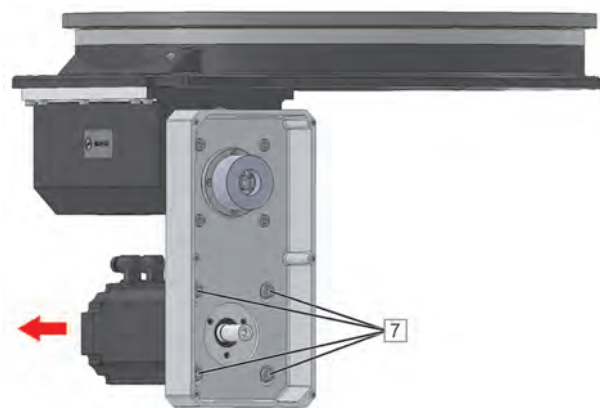

8. Remove the four screws [7] of the motor flange and remove the motor.

Mounting the motor

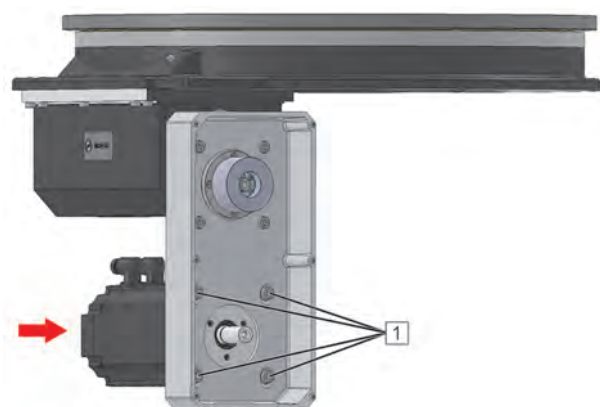

1. Fit the motor with the required position of the electrical connections.
2. Slightly tighten the four screws [1] of the motor flange.
3. Grease the motor shaft.

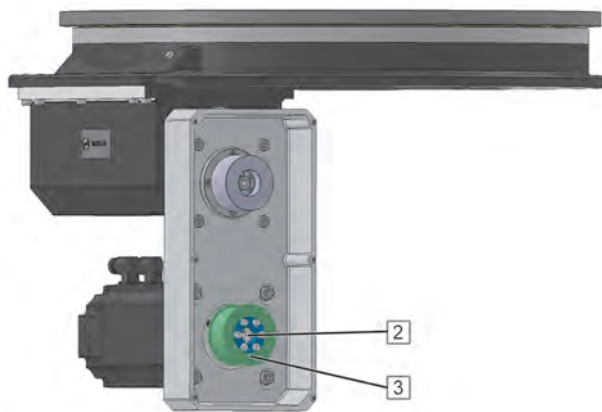

4. Push the toothed belt pulley (motor) [3] onto the motor shaft all the way to the stop. If you encounter resistance, use a plastic hammer.
5. Fit the disk onto the toothed belt pulley (motor) [3] and fasten it with the screws [2].

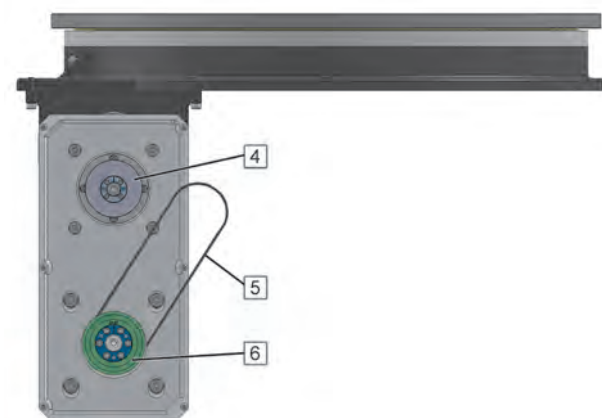

6. First, fit the toothed belt [5] around the toothed belt pulley (motor) [6].
7. Then, fit the toothed belt [5] around the toothed belt pulley (gear) [4].

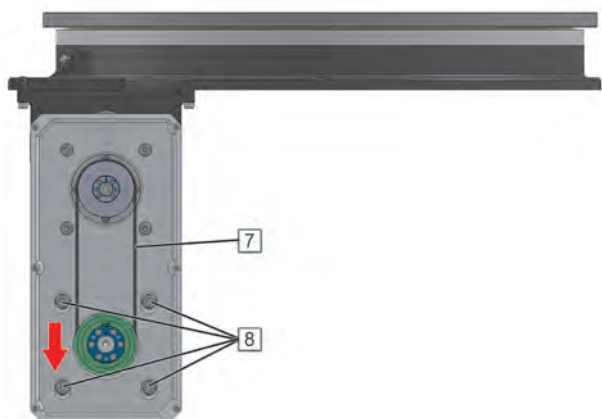

8. Tension the toothed belt [7] to the correct belt tension by moving the motor in the elongated holes and tighten the four screws [8] of the motor flange.
9. Verify correct tension of the toothed belt; if necessary, readjust the tension of the toothed belt.
 - ✓ The toothed belt is correctly tensioned if it can be manually twisted by - depending on the length of the toothed belt - 45° to 90° along the longitudinal axis in the center between the two pulleys.
 - ✓ Contact WEISS GmbH if you need the frequency for adjusting the toothed belt with a belt tension meter.

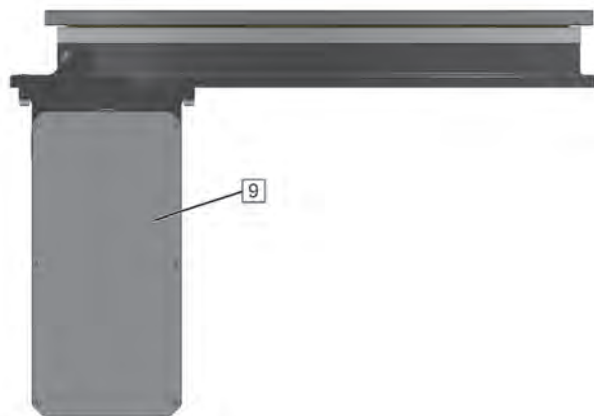

10. Mount the cover [9] by means of the screws.
11. Reconnect the motor and the holding brake (see operating instructions of the motor manufacturer).
12. Remove all tools and equipment.
13. Perform a test run.

15.4 Inspecting the toothed belt



⚠ DANGER

ELECTRIC SHOCK CAUSED BY LIVE PARTS

Failure to follow these instructions will result in death or serious injury.

- Disconnect the mains supply voltage before performing the work and ensure that it cannot be switched on.
- Verify that no hazards can be caused by electrically conductive objects.
- Verify that all cables for the power supply are disconnected from power.



⚠ WARNING

MISSING PROTECTIVE EQUIPMENT

Failure to follow these instructions can result in death, serious injury, and equipment damage.

- Immediately reinstall protective equipment that you may have removed to perform maintenance work after having completed the maintenance work and verify the effectiveness of the protective equipment.



⚠ WARNING

MOVING PARTS

Failure to follow these instructions can result in death, serious injury, and equipment damage.

- Verify that the zone of operation of the moving parts of the product/machine is safeguarded.



⚠ WARNING

HOT SURFACES

The temperature of the motor and the holding brake can exceed 100 °C during operation.

Failure to follow these instructions can result in death, serious injury, and equipment damage.

- Avoid unprotected contact with hot surfaces.
- Do not allow flammable or heat-sensitive objects in the vicinity of hot surfaces.
- Before performing work on the motor or the holding brake, verify that you wait for a sufficient period of time to allow such parts to cool down to a temperature that allows for safe contact.

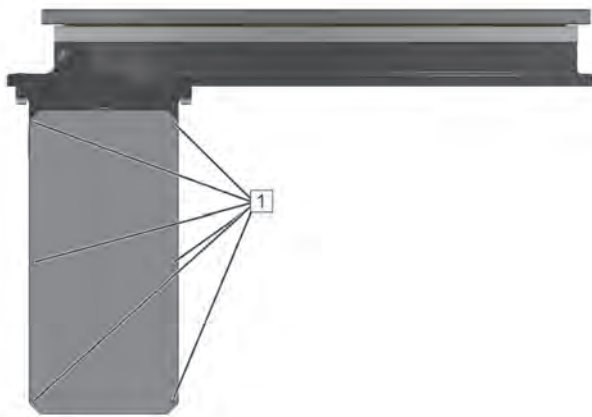

The product must be in a locked position before the toothed belt is inspected.

1. Remove the cover [1] by removing the screws.

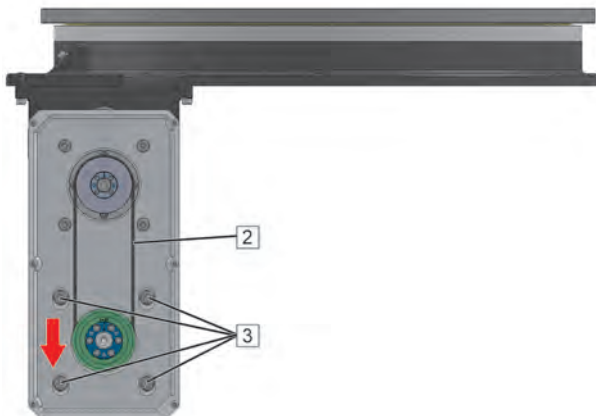

2. Verify correct tension of the toothed belt; if necessary, readjust the tension of the toothed belt.
 - ✓ The toothed belt is correctly tensioned if it can be manually twisted by - depending on the length of the toothed belt - 45° to 90° along the longitudinal axis in the center between the two pulleys.
 - ✓ Contact WEISS GmbH if you need the frequency for adjusting the toothed belt with a belt tension meter.
3. Tension the toothed belt [2] to the correct belt tension by moving the motor in the elongated holes and tighten the four screws [3] of the motor flange.

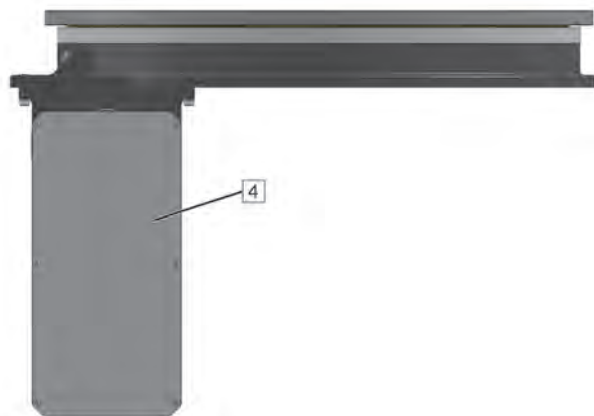

4. Mount the cover [4] by means of the screws.
5. Remove all tools and equipment.
6. Perform a test run.

15.5 Replacing the toothed belt



⚠ DANGER

ELECTRIC SHOCK CAUSED BY LIVE PARTS

Failure to follow these instructions will result in death or serious injury.

- Disconnect the mains supply voltage before performing the work and ensure that it cannot be switched on.
- Verify that no hazards can be caused by electrically conductive objects.
- Verify that all cables for the power supply are disconnected from power.



⚠ WARNING

UNANTICIPATED MOVEMENT OF THE ROTARY RING/THE ROTARY RING

The gear is not self-locking. When the drive and the output flange/rotary ring are decoupled, the output flange/rotary ring can move.

Failure to follow these instructions can result in death, serious injury, and equipment damage.

- Block or safeguard the output flange/rotary ring in such a way that a movement of the output flange/rotary ring is safely prevented before releasing the holding brake or decoupling the drive and the output flange/rotary ring.



⚠ WARNING

MISSING PROTECTIVE EQUIPMENT

Failure to follow these instructions can result in death, serious injury, and equipment damage.

- Immediately reinstall protective equipment that you may have removed to perform maintenance work after having completed the maintenance work and verify the effectiveness of the protective equipment.



⚠ WARNING

MOVING PARTS

Failure to follow these instructions can result in death, serious injury, and equipment damage.

- Verify that the zone of operation of the moving parts of the product/machine is safeguarded.



⚠ WARNING

HOT SURFACES

The temperature of the motor and the holding brake can exceed 100 °C during operation.

Failure to follow these instructions can result in death, serious injury, and equipment damage.

- Avoid unprotected contact with hot surfaces.
- Do not allow flammable or heat-sensitive objects in the vicinity of hot surfaces.
- Before performing work on the motor or the holding brake, verify that you wait for a sufficient period of time to allow such parts to cool down to a temperature that allows for safe contact.

Dismounting the toothed belt

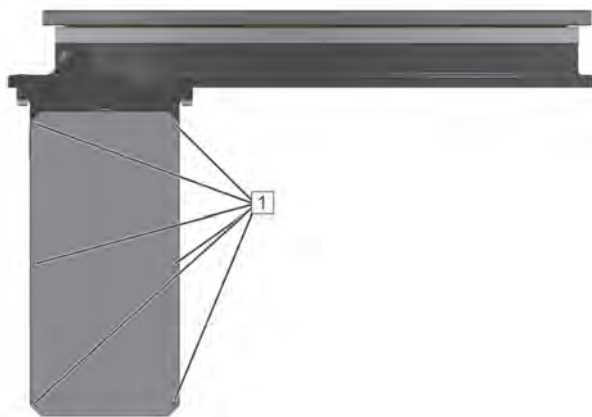

The product must be in a locked position before the toothed belt is replaced.

1. Remove the cover [1] by removing the screws.

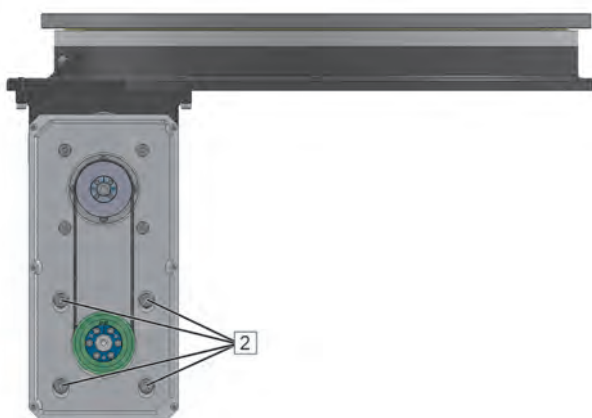

2. Loosen the four screws [2] of the motor flange.

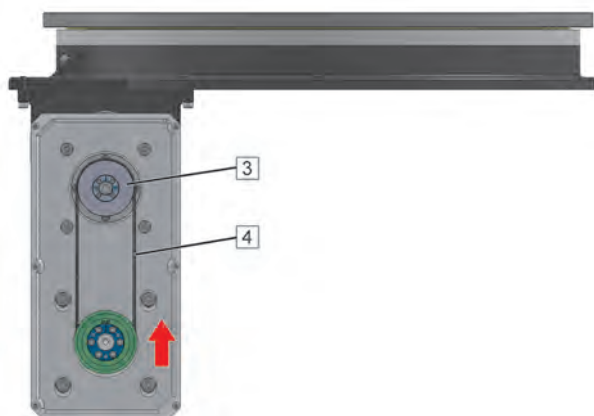

3. Slacken the toothed belt [4] by moving the motor in the elongated holes.
4. To remove the toothed belt [4], start by pulling the toothed belt off of the toothed belt pulley (gear) [3].

Mounting the toothed belt

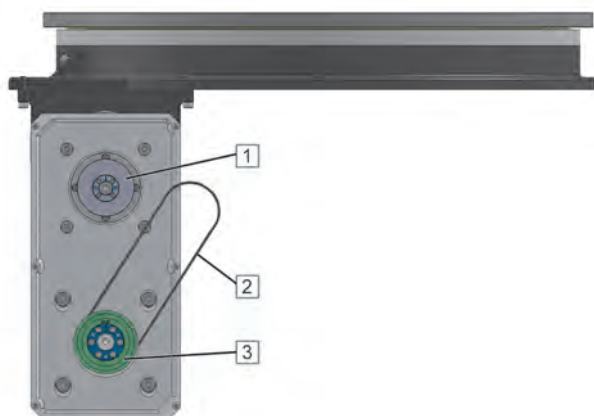

1. First, fit the new toothed belt [2] around the toothed belt pulley (motor) [3].
2. Then, fit the toothed belt [2] around the toothed belt pulley (gear) [1].

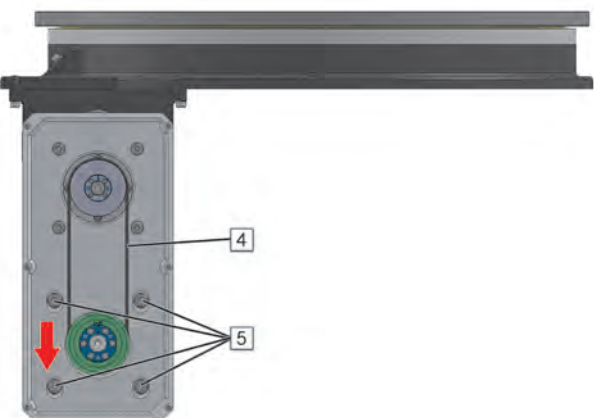

3. Tension the toothed belt [4] to the correct belt tension by moving the motor in the elongated holes and tighten the four screws [5] of the motor flange.
 4. Verify correct tension of the toothed belt; if necessary, readjust the tension of the toothed belt.
- ✓ The toothed belt is correctly tensioned if it can be manually twisted by - depending on the length of the toothed belt - 45° to 90° along the longitudinal axis in the center between the two pulleys.
 - ✓ Contact WEISS GmbH if you need the frequency for adjusting the toothed belt with a belt tension meter.

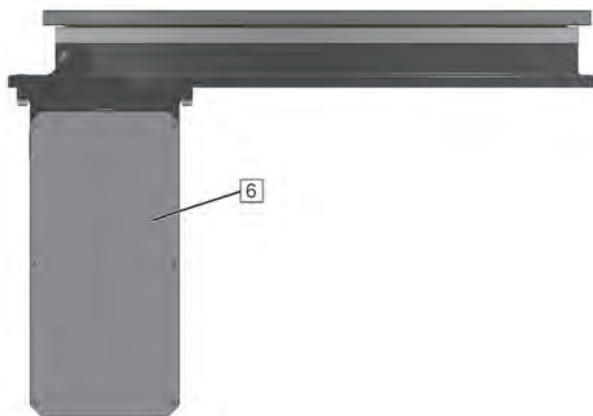

5. Mount the cover [6] by means of the screws.
6. Remove all tools and equipment.
7. Perform a test run.

15.6 Inspecting the holding brake



⚠ DANGER

ELECTRIC SHOCK CAUSED BY LIVE PARTS

Failure to follow these instructions will result in death or serious injury.

- Disconnect the mains supply voltage before performing the work and ensure that it cannot be switched on.
- Verify that no hazards can be caused by electrically conductive objects.
- Verify that all cables for the power supply are disconnected from power.



⚠ WARNING

UNANTICIPATED MOVEMENT OF THE ROTARY RING/THE ROTARY RING

The gear is not self-locking. When the drive and the output flange/rotary ring are decoupled, the output flange/rotary ring can move.

Failure to follow these instructions can result in death, serious injury, and equipment damage.

- Block or safeguard the output flange/rotary ring in such a way that a movement of the output flange/rotary ring is safely prevented before releasing the holding brake or decoupling the drive and the output flange/rotary ring.



⚠ WARNING

MISSING PROTECTIVE EQUIPMENT

Failure to follow these instructions can result in death, serious injury, and equipment damage.

- Immediately reinstall protective equipment that you may have removed to perform maintenance work after having completed the maintenance work and verify the effectiveness of the protective equipment.

**⚠ WARNING****MOVING PARTS**

Failure to follow these instructions can result in death, serious injury, and equipment damage.

- Verify that the zone of operation of the moving parts of the product/machine is safeguarded.

**⚠ WARNING****HOT SURFACES**

The temperature of the motor and the holding brake can exceed 100 °C during operation.

Failure to follow these instructions can result in death, serious injury, and equipment damage.

- Avoid unprotected contact with hot surfaces.
- Do not allow flammable or heat-sensitive objects in the vicinity of hot surfaces.
- Before performing work on the motor or the holding brake, verify that you wait for a sufficient period of time to allow such parts to cool down to a temperature that allows for safe contact.

The holding brake is located between the fan wheel and the end plate of the motor.

Perform a visual inspection of the holding brake every two million cycles or once per year (whichever occurs first).

Check the holding brake for braking force, wear, mechanical issues, and dirt.

Measure the air gap and the brake lining.

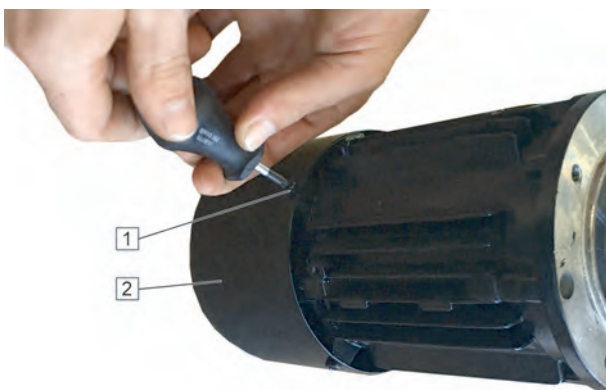

1. Remove all screws [1] of the fan cap [2] and pull off the fan cap [2] from the motor.

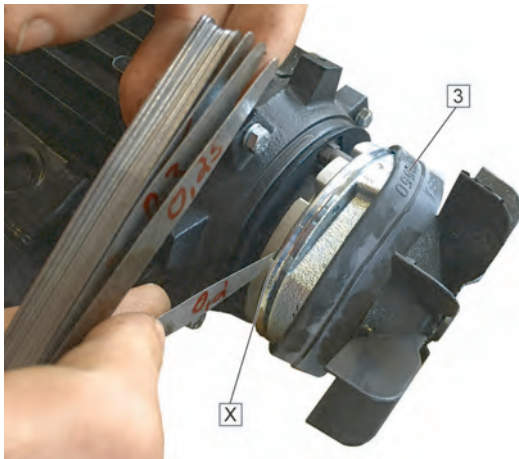

2. Pull the protective rubber [3] towards the fan wheel.
3. Blow out abrasion material with compressed air.
4. Measure the air gap [X] with a feeler gauge. The size of the air gap must not exceed 0.2 mm.
 - ✓ If the size of the air gap exceeds the permissible tolerance value, the air gap must be readjusted, [see chapter 15.7](#).
 - ✓ If it is not possible to adjust the air gap to a size of 0.2 mm, the brake lining or the entire holding brake must be replaced, [see chapter 15.8](#).
5. Pull the protective rubber [3] back into its initial position.
6. Screw the fan cap [2] to the motor.
7. Remove all tools and equipment.
8. Perform a test run.

15.7 Readjusting the air gap of the holding brake



⚠ DANGER

ELECTRIC SHOCK CAUSED BY LIVE PARTS

Failure to follow these instructions will result in death or serious injury.

- Disconnect the mains supply voltage before performing the work and ensure that it cannot be switched on.
- Verify that no hazards can be caused by electrically conductive objects.
- Verify that all cables for the power supply are disconnected from power.



⚠ WARNING

UNANTICIPATED MOVEMENT OF THE ROTARY RING/THE ROTARY RING

The gear is not self-locking. When the drive and the output flange/rotary ring are decoupled, the output flange/rotary ring can move.

Failure to follow these instructions can result in death, serious injury, and equipment damage.

- Block or safeguard the output flange/rotary ring in such a way that a movement of the output flange/rotary ring is safely prevented before releasing the holding brake or decoupling the drive and the output flange/rotary ring.

**⚠ WARNING****MISSING PROTECTIVE EQUIPMENT**

Failure to follow these instructions can result in death, serious injury, and equipment damage.

- Immediately reinstall protective equipment that you may have removed to perform maintenance work after having completed the maintenance work and verify the effectiveness of the protective equipment.

**⚠ WARNING****MOVING PARTS**

Failure to follow these instructions can result in death, serious injury, and equipment damage.

- Verify that the zone of operation of the moving parts of the product/machine is safeguarded.

**⚠ WARNING****HOT SURFACES**

The temperature of the motor and the holding brake can exceed 100 °C during operation.

Failure to follow these instructions can result in death, serious injury, and equipment damage.

- Avoid unprotected contact with hot surfaces.
- Do not allow flammable or heat-sensitive objects in the vicinity of hot surfaces.
- Before performing work on the motor or the holding brake, verify that you wait for a sufficient period of time to allow such parts to cool down to a temperature that allows for safe contact.

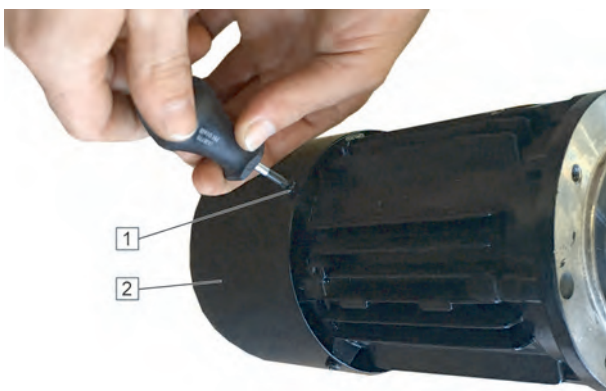

1. Remove all screws [1] of the fan cap [2] and pull off the fan cap [2] from the motor.



2. Remove the circlip [3] from the fan wheel.

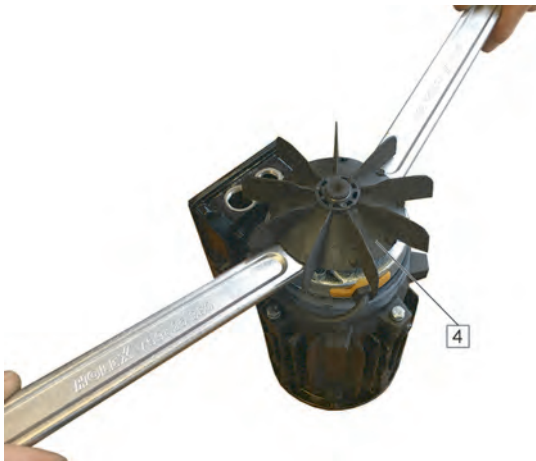

3. Remove the fan wheel [4] with two mounting levers at the inside of the plastic collar.



4. Remove the protective rubber [5].
5. Blow out abrasion material with compressed air.
6. Loosen the screws [6] of the holding brake.

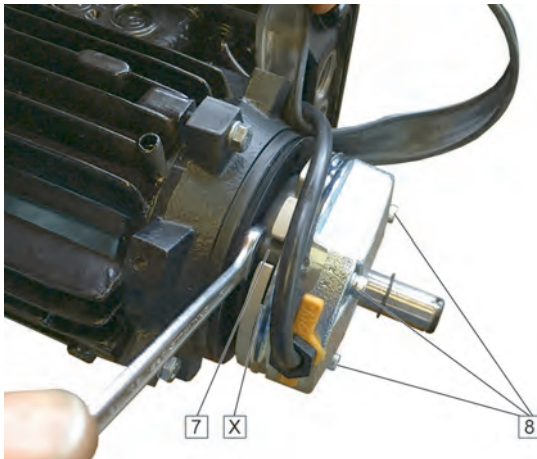

7. Set the air gap [X] around the entire circumference of the brake disc to 0.2 mm by turning the adjusters [7].
8. Tighten the screws [8].

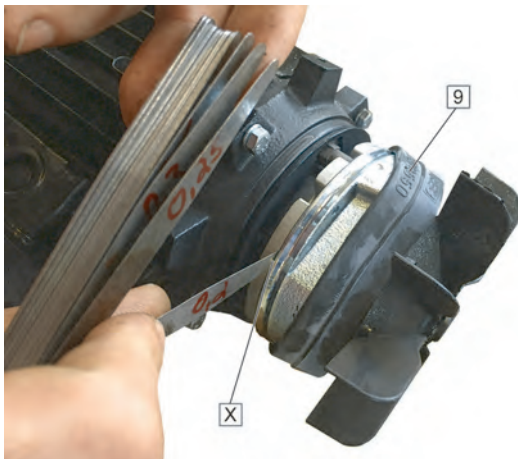

9. Measure the air gap [X] around the entire circumference with a feeler gauge.
10. If the size of the air gap is not 0.2 mm at all positions around the entire circumference, repeat the adjustment procedure.
11. Pull the protective rubber [9] back into its initial position.
12. Refit the fan wheel and secure it with the circlip.
13. Screw the fan cap back to the motor.
14. Remove all tools and equipment.
15. Perform a test run.

15.8 Replacing the holding brake



⚠ DANGER

ELECTRIC SHOCK CAUSED BY LIVE PARTS

Failure to follow these instructions will result in death or serious injury.

- Disconnect the mains supply voltage before performing the work and ensure that it cannot be switched on.
- Verify that no hazards can be caused by electrically conductive objects.
- Verify that all cables for the power supply are disconnected from power.

**⚠ WARNING****UNANTICIPATED MOVEMENT OF THE ROTARY RING/THE ROTARY RING**

The gear is not self-locking. When the drive and the output flange/rotary ring are decoupled, the output flange/rotary ring can move.

Failure to follow these instructions can result in death, serious injury, and equipment damage.

- Block or safeguard the output flange/rotary ring in such a way that a movement of the output flange/rotary ring is safely prevented before releasing the holding brake or decoupling the drive and the output flange/rotary ring.

**⚠ WARNING****MISSING PROTECTIVE EQUIPMENT**

Failure to follow these instructions can result in death, serious injury, and equipment damage.

- Immediately reinstall protective equipment that you may have removed to perform maintenance work after having completed the maintenance work and verify the effectiveness of the protective equipment.

**⚠ WARNING****MOVING PARTS**

Failure to follow these instructions can result in death, serious injury, and equipment damage.

- Verify that the zone of operation of the moving parts of the product/machine is safeguarded.

**⚠ WARNING****HOT SURFACES**

The temperature of the motor and the holding brake can exceed 100 °C during operation.

Failure to follow these instructions can result in death, serious injury, and equipment damage.

- Avoid unprotected contact with hot surfaces.
- Do not allow flammable or heat-sensitive objects in the vicinity of hot surfaces.
- Before performing work on the motor or the holding brake, verify that you wait for a sufficient period of time to allow such parts to cool down to a temperature that allows for safe contact.

Dismounting the holding brake

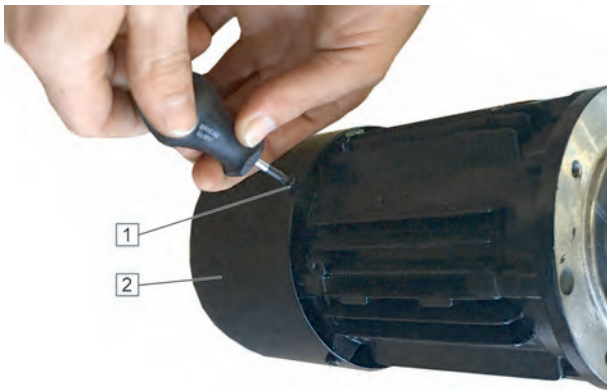

1. Remove all screws [1] of the fan cap [2] and pull off the fan cap [2] from the motor.

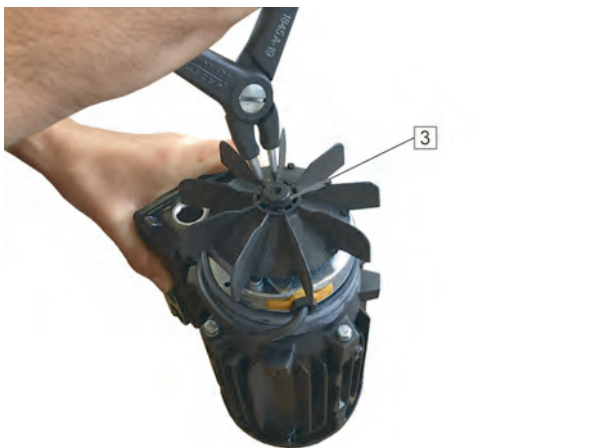

2. Remove the circlip [3] from the fan wheel.

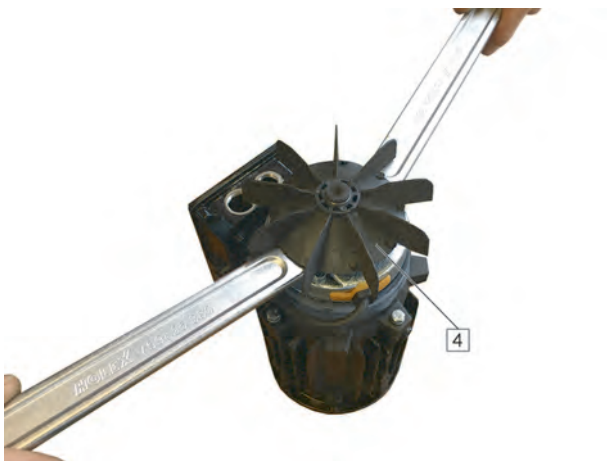

3. Remove the fan wheel [4] with two mounting levers at the inside of the plastic collar.
4. Disconnect the cables of the holding brake in the terminal box of the motor (see operating instructions of the motor manufacturer).



5. Remove the protective rubber [5].
6. Loosen the screws [6] of the holding brake.

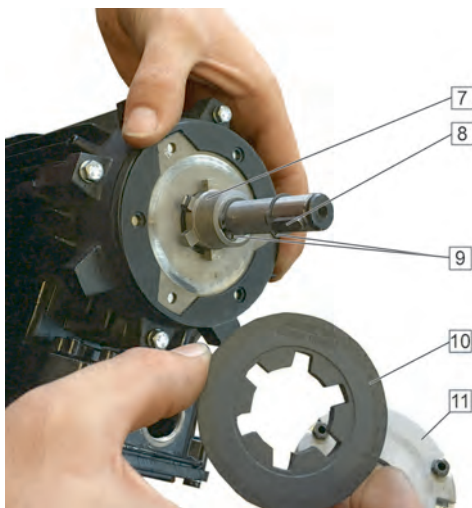

7. Remove the holding brake [11] and the brake lining [10].
8. To remove the hub [7], remove the two circlips [9] and the parallel key [8].
9. Blow out abrasion material with compressed air.

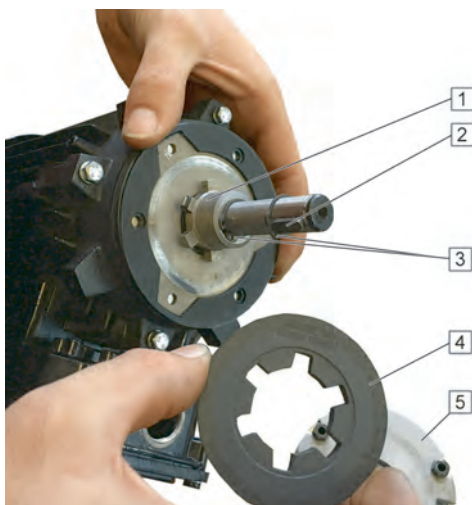
Mounting the holding brake

1. Insert the new hub [1] and fit the two circlips [3] and the parallel key [2].
2. Fit the new brake lining [4] and the holding brake [5].



3. Fasten the holding brake with the screws [6].
4. Adjust the air gap of the holding brake, [see chapter 15.7](#).



5. Pull the protective rubber [7] back into its initial position.



6. Refit the fan wheel and secure it with the circlip [8].

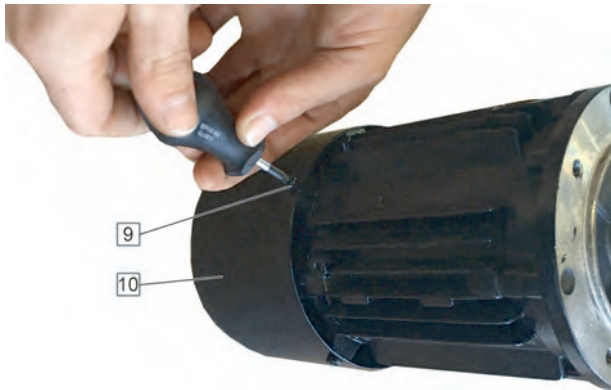

7. Place the fan cap [10] on the motor.
8. Tighten all screws [9] of the fan cap.
9. Connect the cables of the holding brake in the terminal box of the motor (see operating instructions of the motor manufacturer).
10. Remove all tools and equipment.
11. Perform a test run.

15.9 Replacing the inductive sensor



⚠ DANGER

ELECTRIC SHOCK CAUSED BY LIVE PARTS

To perform the work described below, it may be required to release the holding brake.

Failure to follow these instructions will result in death or serious injury.

- Perform the work described below only on products whose holding brake is supplied with 24 V DC.
- Verify that the work described below is performed by the WEISS customer service if the holding brake is supplied with a voltage other than 24 V DC.
- Use an external 24 V DC power supply to release the holding brake.
- Do not switch on the power supply to the product (main switch).
- Prior to performing any work, verify that no mains voltage is applied to the product.
- Verify that releasing the holding brake cannot cause any other hazards.

Dismounting the inductive sensor

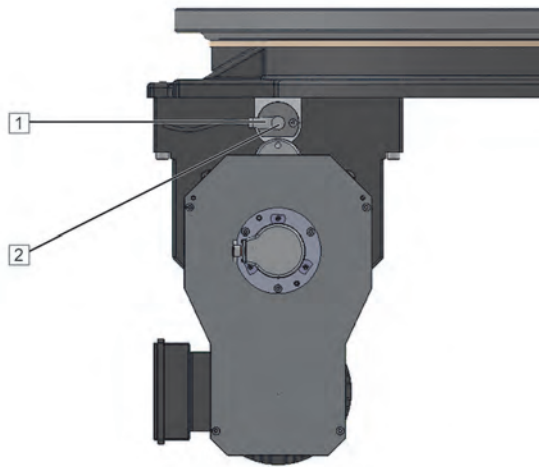

1. Remove the connector [1] from the inductive sensor [2].

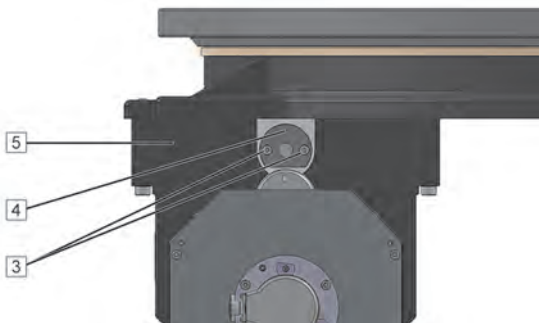

2. Loosen the screws [3] in the limit switch bushing [4].
3. Remove the limit switch bushing with the inductive sensor from the cam housing [5].

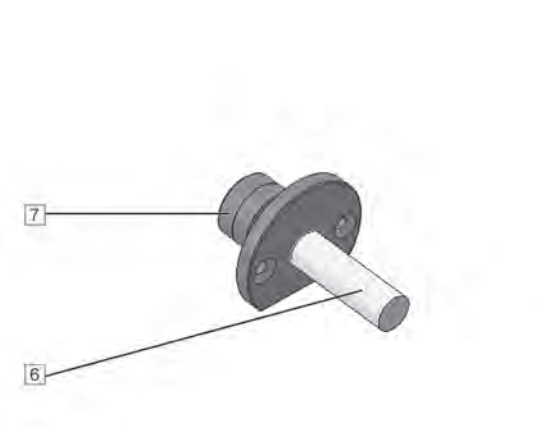

4. Unscrew the inductive sensor [6] from the limit switch bushing [7].
- ✓ The inductive sensor is now uninstalled.

Mounting the inductive sensor

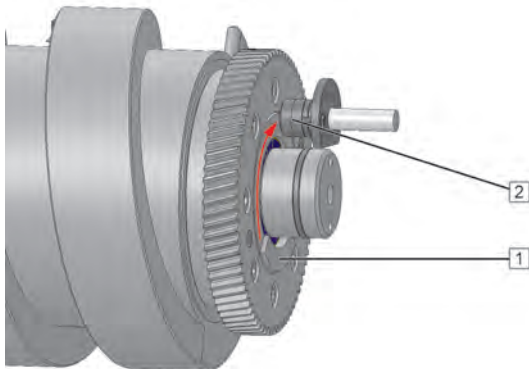

When the inductive sensor is installed, the switching distance between the position cam on the driving cam and the inductive sensor must be adjusted. For this purpose, the position cam must be located opposite the mounting position of the inductive sensor (in the detection area of the inductive sensor).

1. Look at the driving cam through the opening in which the bushing of the limit switch was previously installed.
2. Verify that the position cam [1] faces the mounting position of the inductive sensor [2].

If the position cam does not face the mounting position of the inductive sensor, you must pull the toothed belt until the position cam is directly opposing the mounting position of the inductive sensor.

The position of the position cam can only be changed if the holding brake has been released. The holding brake can only be released by applying the brake voltage. Use an external 24 V DC power supply to apply the brake voltage.

- Connect an external 24 V DC power supply to the terminals of the holding brake.
- Apply 24 V DC to the holding brake.
- Pull the toothed belt until the position cam is directly facing the inductive sensor.
- Disconnect the external 24 V DC power supply from the terminals of the holding brake.
- Verify that the holding brake has been properly applied before continuing your work.

3. Apply surface sealant (such as Teroson Fluid D Universal) to the thread of the new inductive sensor.
4. Screw the (new) inductive sensor [3] into the the limit switch bushing [4].

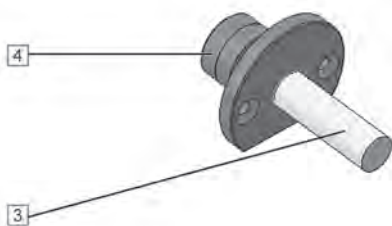

The head of the inductive sensor must protrude from the limit switch bushing by approximately 1 mm (dimension [A]).

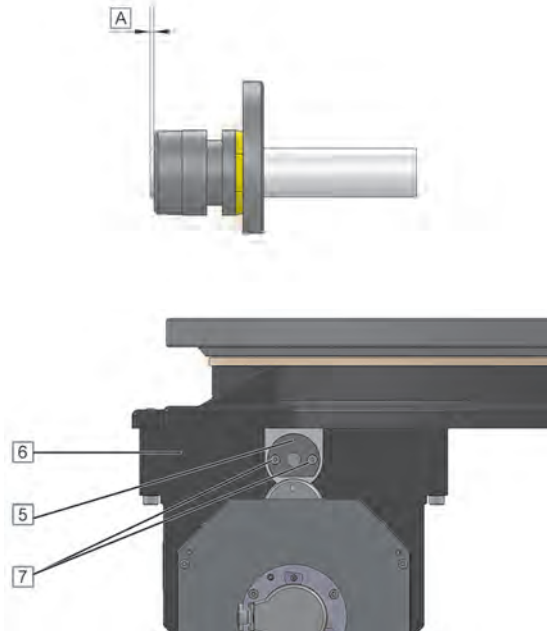

5. Fit the limit switch bushing [5] with the inductive sensor into the cam housing [6].
6. Tighten the screws [7].
7. Manually turn the inductive sensor clockwise into the limit switch bushing until the head of the inductive sensor is in contact with the position cam.

8. **For TR0750A:**
Manually turn the inductive sensor counter-clockwise by three thirds of a revolution out of the limit switch bushing.

✓ The switching distance amounts to approximately 0.5 mm.

9. **For TR1100A, TR1500A, TR2200A:**
Manually turn the inductive sensor counter-clockwise by two revolutions out of the limit switch bushing.

✓ The switching distance amounts to approximately 2 mm.

10. Secure the inductive sensor with the nut.

11. Plug the connector [8] onto the inductive sensor [9].

12. Remove all tools and equipment.

13. Perform a test run.

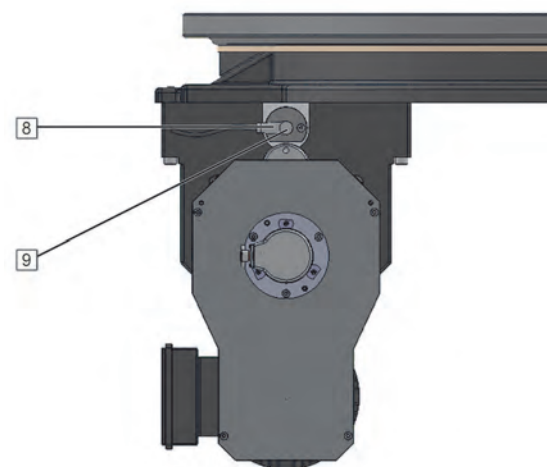

16 Decommissioning

16.1 Decommissioning the product

1. Switch off the product and secure it against unintended switching on.
2. Remove all workpieces and all other objects not belonging to the product from the product.
3. In the case of recommissioning, follow the instructions described, [see chapter 11](#).

17 Dismounting

17.1 Dismounting the product



⚠ WARNING

FALLING, TOPPLING, OR LOWERING LOADS

Insufficiently rated load lifting and handling equipment may break. Transportation vehicles, lifting gear, chains, belts, and other equipment not rated for the product may fail or tilt.

Failure to follow these instructions can result in death, serious injury, and equipment damage.

- Only use transportation vehicles, lifting gear, chains, belts, and other lifting and handling equipment that comply with all applicable regulations and that are rated for the weight of the product including packaging.
- Verify that there are no persons in the danger zone.
- Verify that the product is properly secured against falling and toppling.

1. Switch off the supply voltage.
2. Dismount the product, [see chapter 8](#) reverse sequence of steps.

18 Disposal

18.1 Disposing of the product

Dispose of the product in compliance with all applicable directives, standards, and safety regulations.

Environmental protection

Dispose of lubricants, greases, residue of cleaning agents and other non-recyclable materials according to the applicable directives, standards, and safety regulations.

19 Service and spare parts

19.1 Worldwide service

If you need the assistance of our service departments, please provide the following information:

- Serial number of the product (see nameplate)
- Description of the problem
- Time of occurrence and circumstances of the problem
- Suspected cause

GERMANY

WEISS GmbH
Siemensstraße 17
74722 Buchen/Odenw.
Phone +49-6281-5208-5999
Fax +49-6281-5208-99
E-mail info@weiss-gmbh.de

SWITZERLAND

WEISS Schweiz GmbH
Friedhofstraße 7
2540 Grenchen
Phone +41-32-6536010
Fax +41-32-6536011
E-Mail info@weiss-gmbh.ch

NETHERLANDS

WEISS Nederland
Kruisstraat 4
7573 GJ Oldenzaal
Phone +31-541-853524
E-mail info@weiss-gmbh.nl

POLAND

WEISS Poland Sp. z o. o.
ul. Wielicka 250
30-663 Kraków
Phone +48-12-281-23-62
Fax +48-12-281-23-63
E-Mail info@weiss-poland.com

ITALY

WEISS Italia S.r.l.
Via dell'Arcoveggio 49/5
40129 Bologna
Phone +39-51-0474967
E-mail info@weiss-italia.it

USA | CANADA

WEISS North America, Inc.
3860 Ben Hur Avenue, Suite 3
Willoughby, OH 44094
Phone +1-888 WEISSNA (888-934-7762)
Fax +1-440-269-8036
E-mail info@weissna.com

SPAIN

WEISS España
Tecnología en máquinas especiales, S.L.
Avda. Juan Carlos I, N°13, 3ªA „Torre Garena“
28806 Alcalá de Henares (Madrid)
Phone +34-91-830-06-86
Fax +34-91-830-06-87
E-mail info@weiss-gmbh.es

UNITED KINGDOM

WEISS UK Ltd.
Meridian House
Winsford Ind Estate
Winsford
Cheshire
CW7 3QG
Phone +44-1606-8605-67
E-mail info@weiss.uk.com

INDIA

WEISS Automation Solutions India Pvt. Ltd.
Office No. 101
Navale IT Park
Survey No. 51/2A/2
Nahre, Pune -411041
Phone +91-20-2469-9810
E-mail info@weiss-india.com

BRASIL

WEISS Brasil Ltda
Rod. BR 280 KM 43, n.º 501 - 3.º Pavimento,
Poço Grande, Guaramirim - SC
Caixa Postal n.º 57 - Cep 89270 - 000
Phone +55-47-99914-9681 ou
+55-47-99971-1554
E-mail info@weiss-brasil.com

ASIA

WEISS Asia
Automation and Components Pte Ltd
18 Boon Lay Way
#07-112
TradeHub 21
Singapore 609966
Phone +65-6570-3274
Fax +65-6684-6757
E-mail info@weiss-asia.com

KOREA

WEISS Korea Co., Ltd.
213-ho, 448, Aenggogae-ro, Namdong-gu,
Incheon, Republic of Korea (21697)
Phone +82-32-228-5208
Fax +82-32-228-5209
E-mail sales@weiss-korea.com

CHINA

WEISS AUTOMATION TECHNOLOGY
(SHANGHAI) CO., LTD.
中国区总部/ Head Office in China
上海/ Shanghai
地址: 上海市嘉定区马陆镇思诚路
1250号8号楼
ADD: Building 8, No.1250 Sicheng Rd., Jiading
District
Phone +86-21-6076-7688 (总机 / Call Center)
Fax +86-21-6076-7699
E-mail info@weiss-china.com

19.2 Ordering spare parts



⚠ WARNING

UNSUITABLE SPARE PARTS AND ACCESSORIES

Failure to follow these instructions can result in death, serious injury, and equipment damage.

- Only use spare parts and accessories which are approved by the manufacturer.

Please provide the following information when ordering spare parts:

- Serial number of the product (see nameplate)
- Part number of the spare part according to spare parts list
- Quantity of spare parts required



**INSPIRING PEOPLE
GREAT SOLUTIONS**

WEISS GmbH

Siemensstraße 17 74722 Buchen
Telefon 06281 5208-0 Telefax 06281 5208-99
info@weiss-international.com
www.weiss-international.com